

# Residential Accessory Structures

Based on the 2009 International Residential Code (IRC)

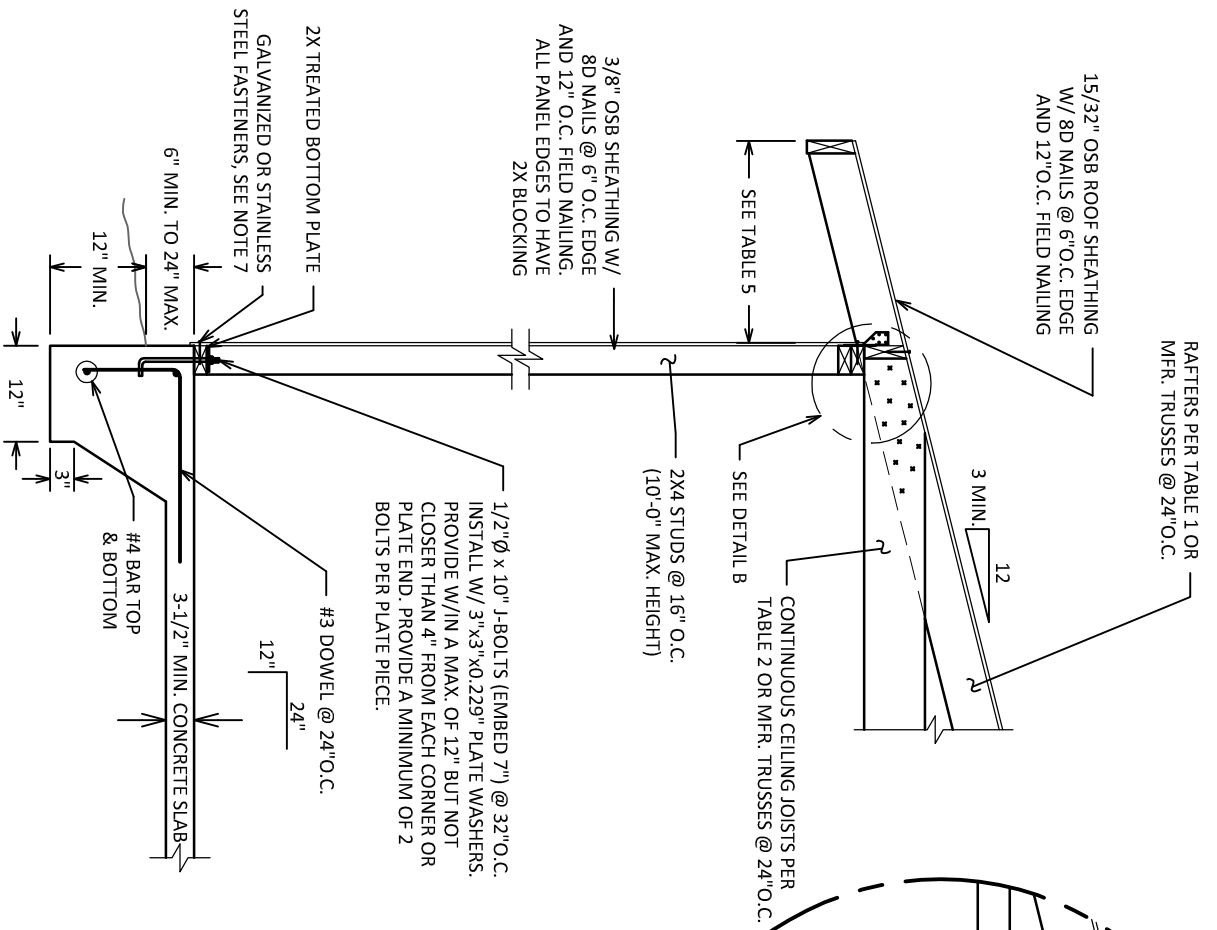

TYPICAL WALL SECTION

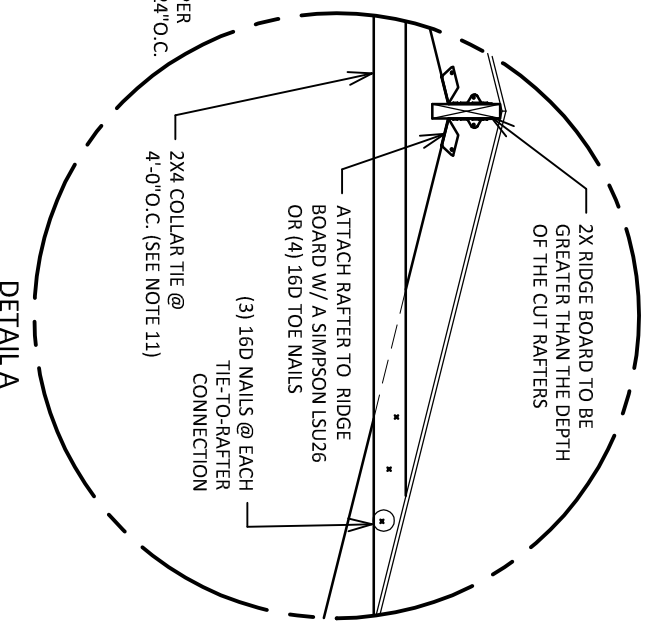

DETAIL A

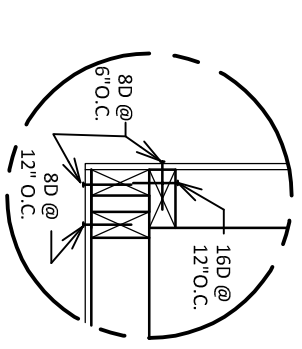

DETAIL C - TYP. WALL CORNER (PLAN VIEW)

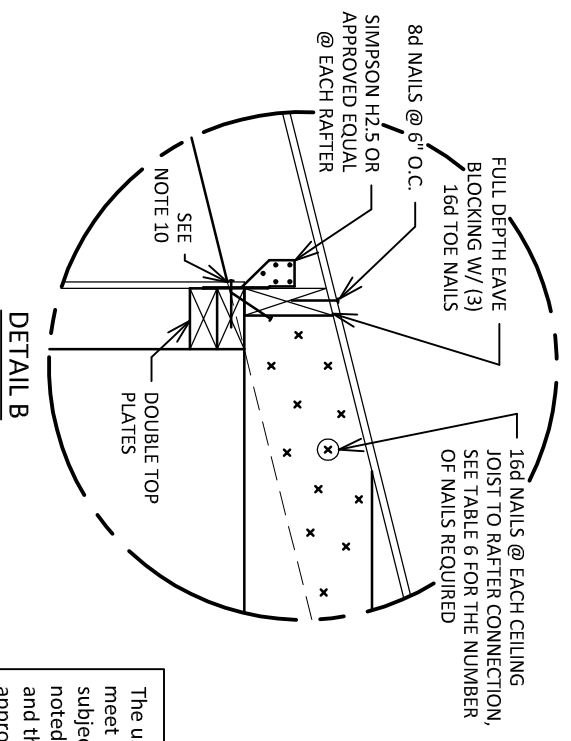

DETAIL B

The use of this handout to meet IRC requirements is subject to the limitations noted in the "General Notes" and the discretion and approval of the authority having jurisdiction.

## GENERAL NOTES

### 1. LIMITATIONS

- This handout provides a simplified approach meeting the prescriptive framing requirements of the IRC. The building department takes no responsibility for the design included herein. If the owner wishes to use this handout, they claim full liability.
- This handout is meant for residential accessory structures only. Said structures are not to exceed 600 square feet and are limited to one-story. The maximum width/length shall be no more than 30-feet. If greater than 20-feet, manufactured trusses must be used in lieu of rafters. The following maximum loads are considered: 50psf ground snow load, 20psf roof dead load, and 20psf attic live load.

### II. CONSTRUCTION

- All concrete shall have a minimum compressive strength of 3,000psi having a maximum slump of 5-inches.
- Remove all vegetation, top soil, and foreign materials from beneath the foundation and floor slab area prior to placing concrete. Footings shall be placed on properly compacted natural soil or structural fill.
- All items to be cast in concrete such as reinforcing, anchor bolts, etc. shall be securely tied in place prior to the placement of concrete. Installation after pour (i.e. "wet-setting") is not allowed.
- No window or door openings are to occur within 2-feet of the building corners.
- Exterior walls w/in 5-feet of the property line, and eaves w/in 4-feet of the property line, shall have a 1-hour fire resistance rating.
- All nails are to be common, box, or deformed shanks. Fasteners in preservative treated wood shall be galvanized or stainless steel.
- See Table 3 for window and door headers. Multiple header plies are to be attached using two rows of 16d nails @ 16" O.C. Install 1/2" filler between plies. All lumber is to be Douglas-Fir Larch #2 or better. Each end of header is to be supported by two jack studs.
- The garage door header can be used for openings between 6- and 18-feet. This header may only be used on non-bearing walls. The two plies are to be attached using two rows of 16d nails @ 16" O.C.
- If notched, the minimum rafter depth @ the wall shall be 4".
- Collar ties are to be located w/in the upper 1/3 of the attic space.
- Splices of double top plates must overlap a minimum of 24-inches. Face nail each end of splice w/ a minimum of (12) 16d nails.
- Solid blocking @ 8'-0" O.C. is required for rafters and joists that are 2x10 or greater.
- Attic ventilation is required if installing a ceiling.
- Roofing shall consist of asphalt shingles and underlayment attached to a sheathed roof deck. Installation must conform to the manufacturers requirements. Underlayment should be labeled to conform to ASTM Standards D226 Type I, D4864 Type I, or D6757.

TABLE 1 - RAFTERS

Member	Spacing	Max. Span
2X4	24" O.C.	5'-0"
	16" O.C.	6'-2"
2X6	24" O.C.	7'-4"
	16" O.C.	9'-0"
2X8	24" O.C.	9'-4"
	16" O.C.	11'-5"
2X10	24" O.C.	11'-5"
	16" O.C.	13'-11"

TABLE 3 - HEADERS

Member	Max. Span
(2) 2X4	2'-8"
(2) 2X6	3'-11"
(2) 2X8	5'-0"
(2) 2X10	6'-1"
(2) 2X12	7'-0"

TABLE 6 - RAFTER/CEILING JOIST NAILS

Rafter Slope	Rafter Spacing	Number of 16d Face Nails Required
3:12	24" O.C.	16
	16" O.C.	11
4:12	24" O.C.	12
	16" O.C.	8
5:12	24" O.C.	10
	16" O.C.	7
7:12	24" O.C.	7
	16" O.C.	5
9:12	24" O.C.	6
	16" O.C.	4

TABLE 4 - NARROW WALLS

Wall Height	B
8'-0"	35" min.
9'-0"	36" min.
10'-0"	33" min.

Wall Height	B
8'-0"	35" min.
9'-0"	36" min.
10'-0"	33" min.

TABLE 2 - CEILING JOISTS

Member	Spacing	Max. Span
2X4	24" O.C.	7'-2"
	16" O.C.	8'-9"
2X6	24" O.C.	10'-6"
	16" O.C.	12'-10"
2X8	24" O.C.	13'-3"
	16" O.C.	16'-3"
2X10	24" O.C.	16'-3"
	16" O.C.	19'-10"

TABLE 5 - MAX. EAVE

Distance to Property Line	Max. Eave
5'-0"	3'-0"
4'-0"	2'-0"
3'-0"	1'-0"
2'-0" or less	0'-4"

This handout is applicable to residential accessory structures that are no greater than 600 square feet. A copy of this handout must be kept at the job site and available to the inspector throughout the construction process.

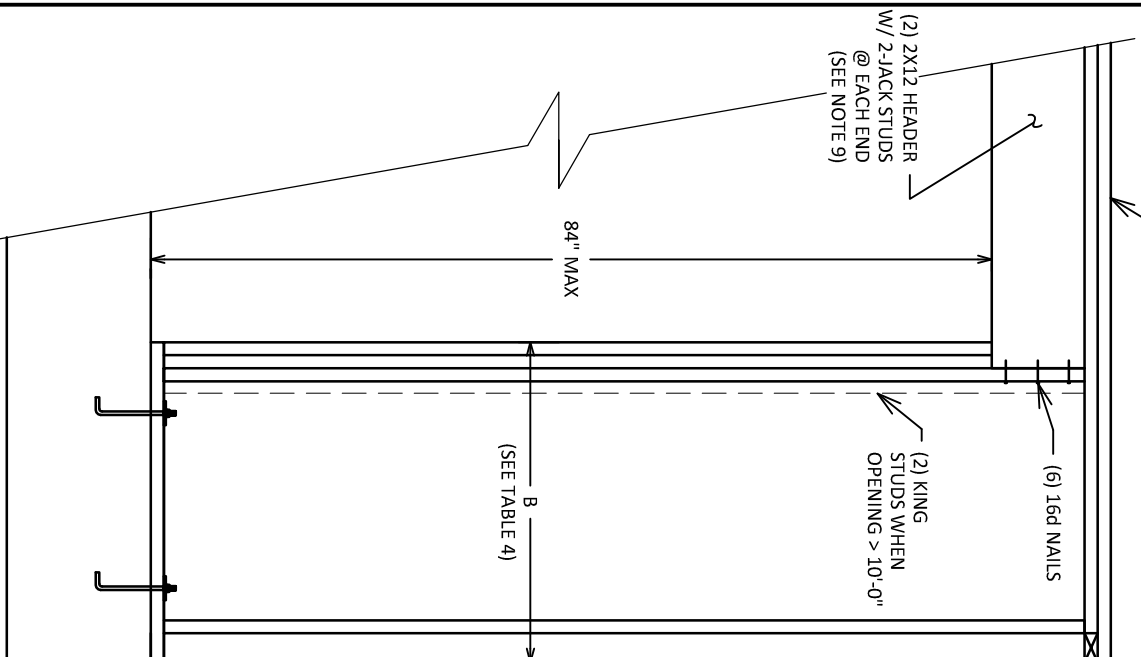

TYPICAL GARAGE OPENING