

**Fencing Guidelines**



# Fencing Guidelines

Ranches HOA, Eagle Mountain, Utah

## Table of Contents

- Approval, Install & Maintenance Process .....3
- 1. Create Fencing Plan.....3
- 2. Submit to HOA for Approval .....3
- 3. Receive Approval .....3
- 4. Build according to Plan within Timeframe.....3
- 5. Maintaining Fence .....3
- 6. Company Options .....3
- Types of Fencing .....4
- 1. Interior Privacy Fencing.....4
- 1.1 Entry Level.....4
- 1.2 Move Up.....6
- 1.3 Semi Custom, Custom, Estate .....6
- 2. Golf Course / Residential Boundary Fence .....7
- 3. Alley Fencing .....8
- 4. Corner Lot Fencing .....11
- 4.1 Rear Yard backing Rear Yard.....11
- 4.2 Rear Yard backing Front Yard .....12
- 5. Open Space Fencing .....12
- 6. Trex Fencing .....13
- Minimum Fence Style Allowed in Each Subdivision .....14
- Sloped Areas.....15
- Unacceptable Fencing .....16



# Fencing Guidelines

Section 8.4, page 53 of the Design Guidelines.

## Approval, Install & Maintenance Process

### 1. Create Fencing Plan

Fencing Plans need to be submitted and approved prior to installation. The following is needed on your fencing plan.

- Drawing of your property and where the fence will be.
- The dimension of the fence on the property, including setbacks from the front of home
- The Style of Fence
- Proposed Date of Completion

### 2. Submit to HOA for Approval

HOA members can submit the plans to the HOA office at any time during regular business hours. The HOA office address and & phone number is 3688 E. Campus Dr. #101 Eagle Mountain, UT 84005 (801) 789-7900.

### 3. Receive Approval

If, after review, the submitted landscaping plan satisfy the fencing requirements, approval shall be granted. The Plan will be stamped as approved and a copy given back to the HOA member. If the submitted plan does not meet requirements, revisions shall be made or a variance may be requested to the Design Review Committee.

### 4. Build according to Plan within Timeframe

Fences need to be built within the timeframe approved.

- Fences need to be stained within **30 days of installation**.
- The entire fence needs to be stained (inside and out). No stain other than **Monterey Grey** is accepted.
- Fence stain must meet "Quality Standards" of the Design Review Committee.
- Higher quality fence stain has been shown to last longer and therefore not requiring staining as often as lesser quality stains.
- Whoever pays for the fence is responsible for staining the fence for the first time.

### 5. Maintaining Fence

All fences need to be maintained.

- HOA will inspect fences to ensure proper maintenance; fines may be imposed for violations.
- After initial stain, any home that neighbors a fence is responsible to maintain and re-stain the fence.
- Recommend re-staining after first 2 years and then every 3-5 years to maintain life of the fence.
- Fence stain must meet "Quality Standards" of the Design Review Committee.
- It is recommended that communication between neighbors occur in order to satisfy the above requirements.

### 6. Company Options – Companies that provide Ranches Quality

Build Approved Fencing	Provide Quality Stain
CFC Fences @ 801-374-1017 Z.A. Quality Fencing @ 801-661-0838	Jones Paint and Glass (Ryan) @ 801-756-5282 Columbia Paint @ 801-434-4180 Natural Woods @801-765-0600 Kwal Paint @ 801-756-1910

## Types of Fencing

### 1. Interior Privacy Fencing

- Privacy fences are 6 feet in height.
- Fencing may be constructed of any species of wood that will stain to match the Ranches standard color – Monterey Grey.
- Trex Privacy Fencing is an approved fencing with specific guidelines. (See page 13)
- All fencing must be setback a minimum of (4) four feet from the front of the home. Where porches exist, a minimum set back of 2 feet from the rear of the porch is allowed. When obstructions exist that make it difficult to meet the setback requirements (e.g. window wells, meters, etc.), a variance may be requested from the Design Review Committee. (See figure below)
- All front yard fencing is prohibited.
- Special fencing rules apply for corner lots, alley lots, and lots adjacent to open space. See Corner, Alley Lot or Open Rail fencing.
- Due to wind, the HOA recommends using 6"x6" cedar post and cementing in the posts a minimum of 2 feet in the ground.

### Gate Style

- All gates should follow the same style as the fence installed.
- Decorative Elements or styles are allowed with Design Review Committee approval.

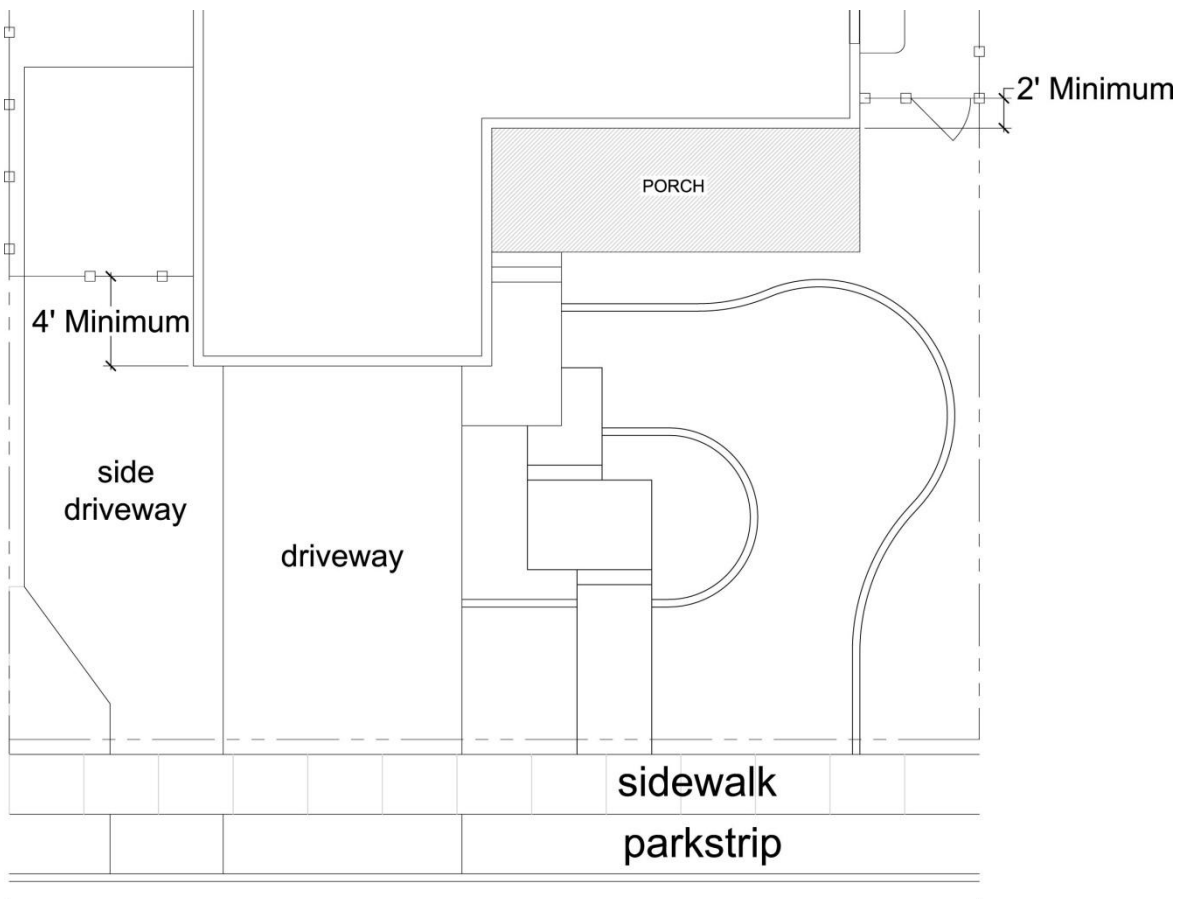

1.1 Entry Level

- Built with 4" x 4" cedar posts that are crowned and routed on top; 1" x 4" and 2" x 4" nailer board on the top and bottom of fence; 2" x 4" cap board on top; and 1" x 6" slats. See diagram.

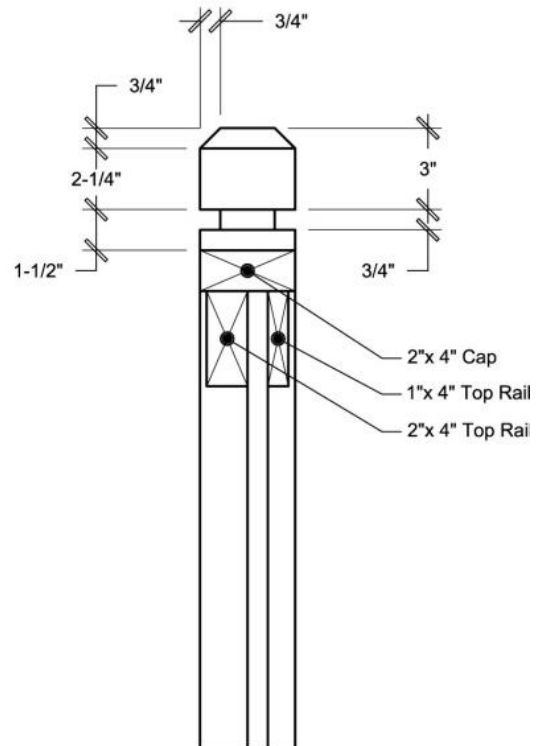
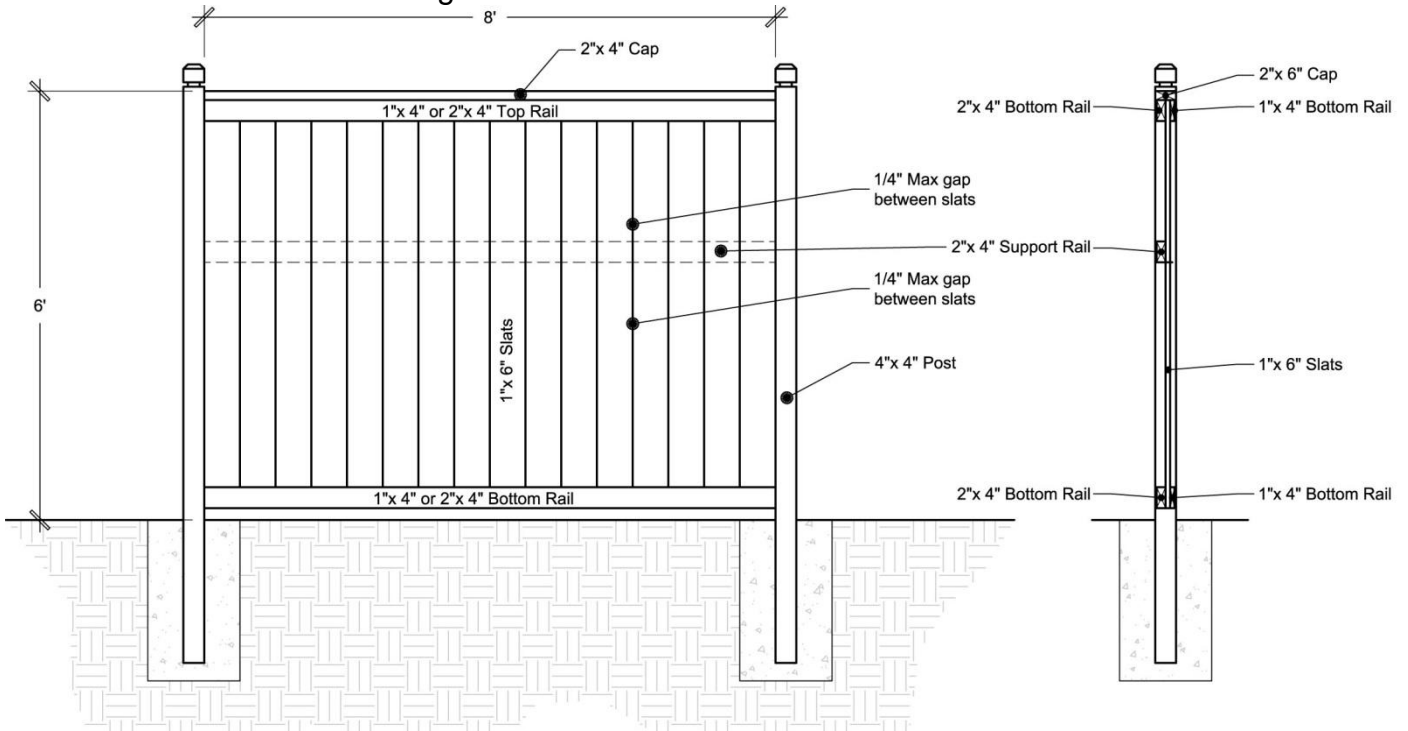

1.2 Move Up

- Built with 4" x 4" or 6" x 6" cedar posts that are crowned and routed on top; 1" x 4" and 2" x 4" nailer board on the top and bottom of fence, 2" x 4" cap board on top, 1" x 6" slats; and 1" x 8" and 2" x 8" nailer board 30" below the top of the fence

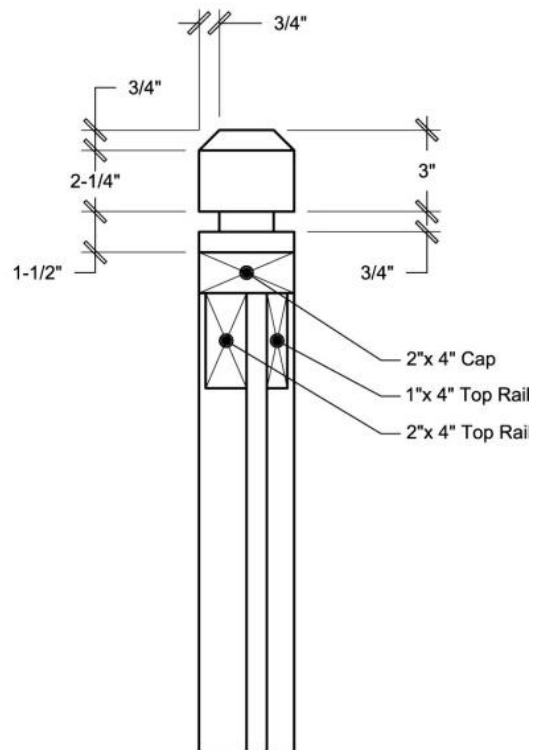
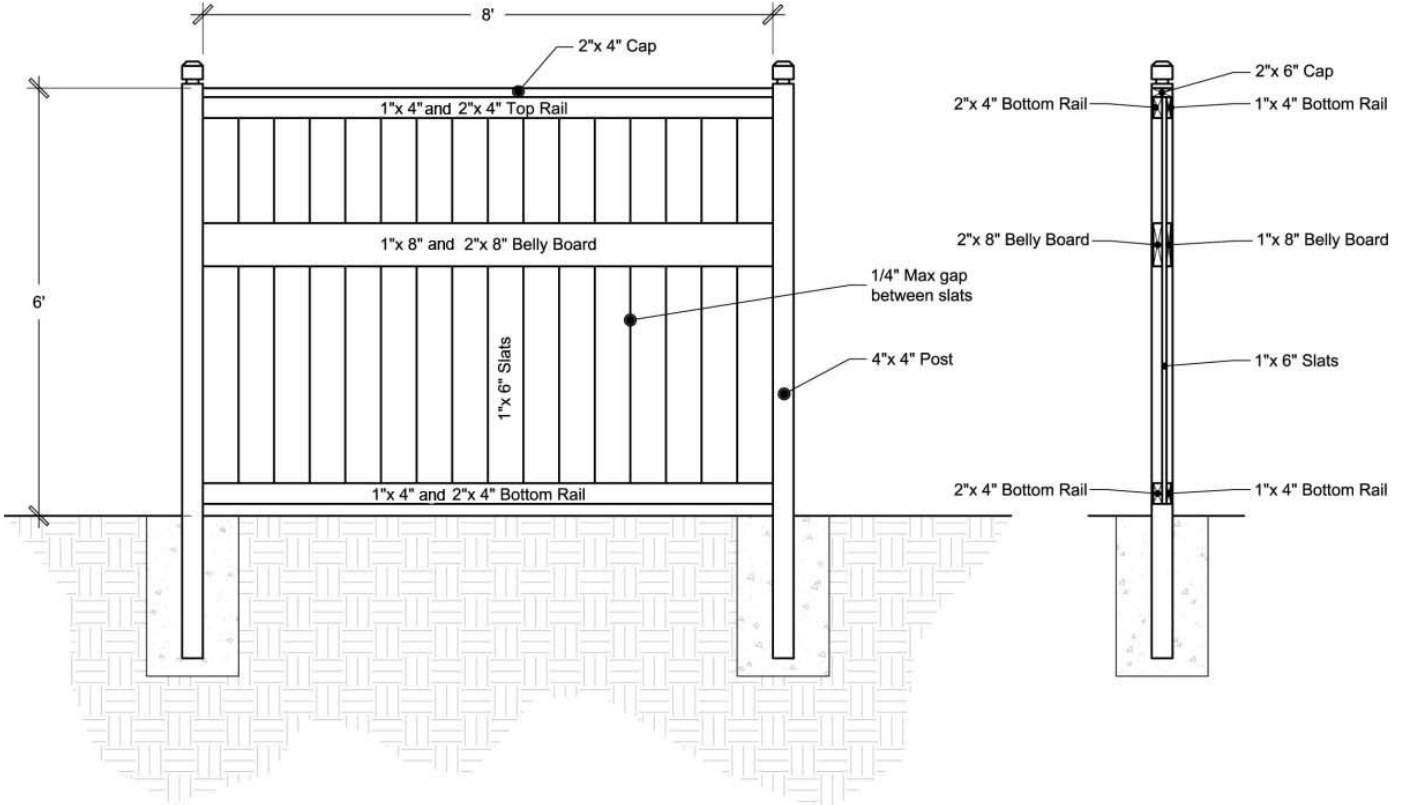

1.3 Semi Custom, Custom, Estate

- Built with 6" x 6" cedar posts that are crowned and routed on top; 1" x 4" and 2" x 4" nailer board on the top and bottom; 2" x 6" cap board on top; 1" x 6" slats that overlap; 1" x 8" and 2" x 8" nailer board 30" below the top of the fence

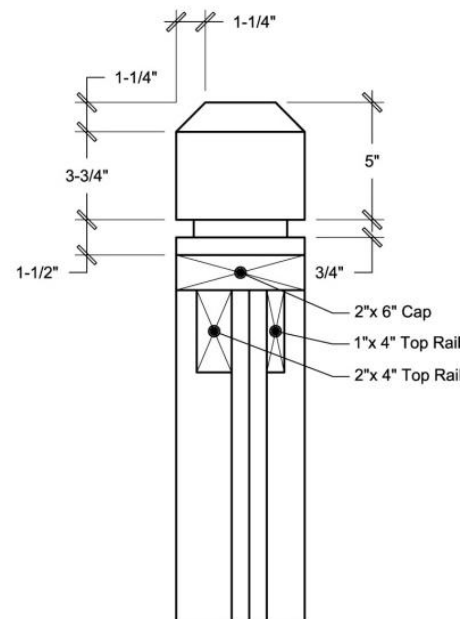
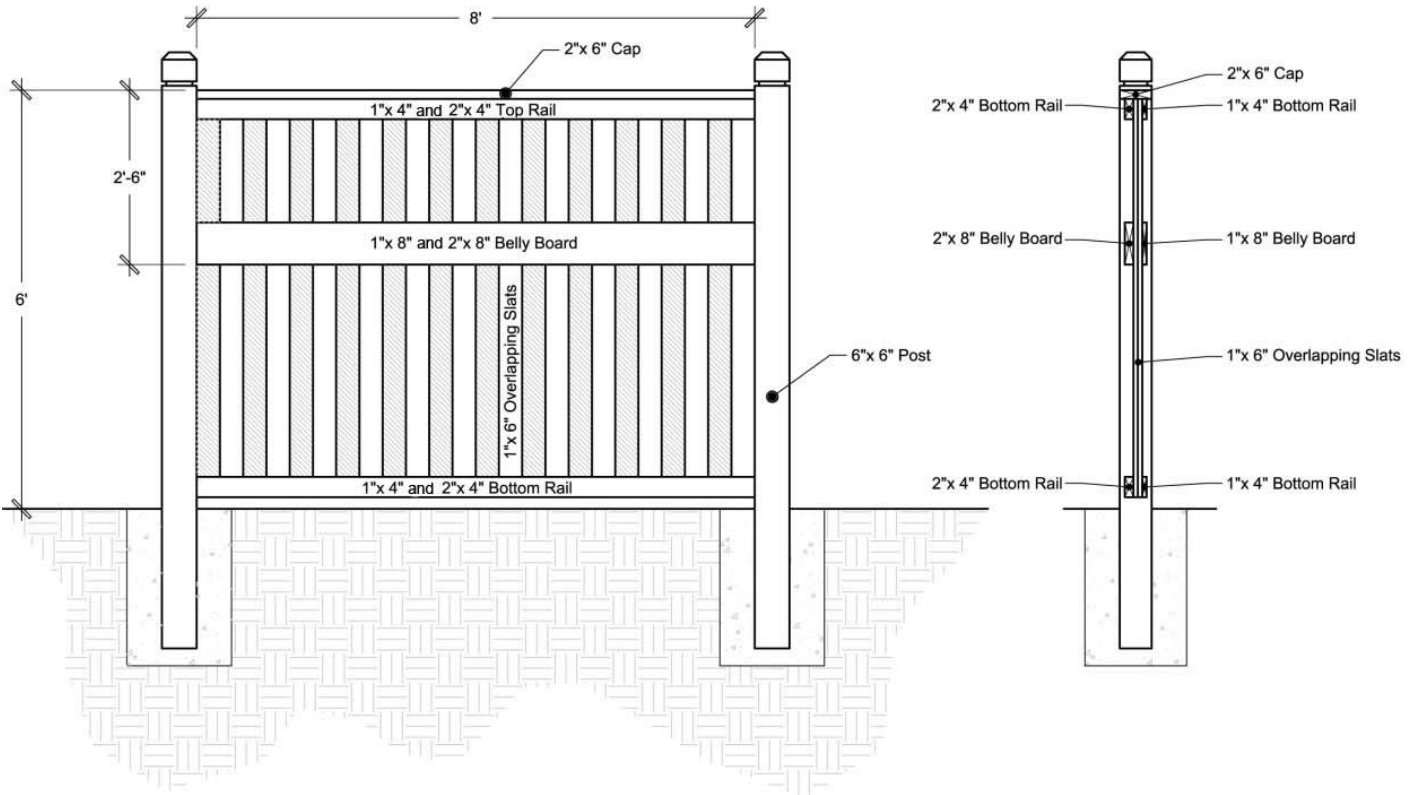

## 2. Golf Course / Residential Boundary Fence

- This is **only** used when a fence is adjacent to the golf course.
- Installed along all boundary areas between the golf course and residential lots.
- Made with 6" x 6" cedar posts that are crowned and routed on top and approx. 6' x 8' metal open rail fence (see illustration for details).

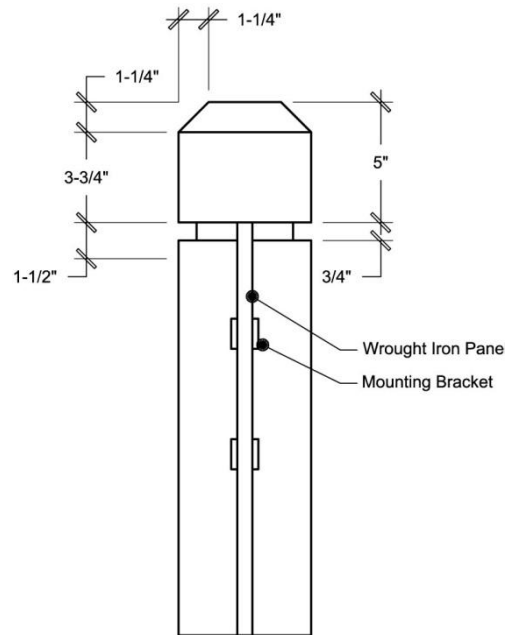
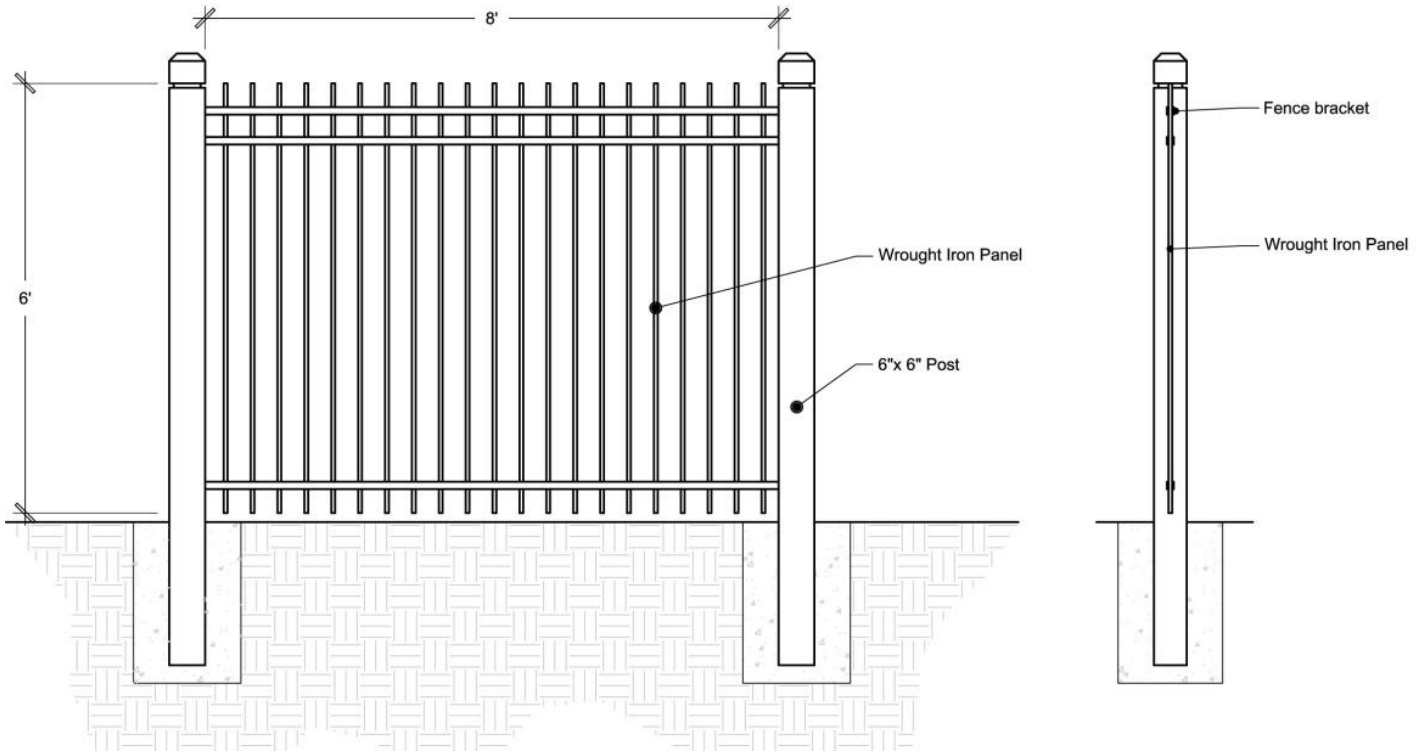

### 3. Alley Fencing

- Alley fence is **only** required when a fence parallels the alley.
- Alley fence must be setback a minimum of 2 feet from the back of curb.
- Where fencing is placed near a driveway or intersection the fence must follow Eagle Mountain City “Line of Site” requirements. Please contact Eagle Mountain City Planning department for more details. Eagle Mountain Code Section 17.60.140.
- Please review the “Line of Site” Illustrations for guidance on how you may follow these City requirements.
- Alley fence is not required if the fence is set back 11’ or more from the back of the alley.
- There are three options for alley fencing. See the following diagrams for options.

Alley Fence Option #1

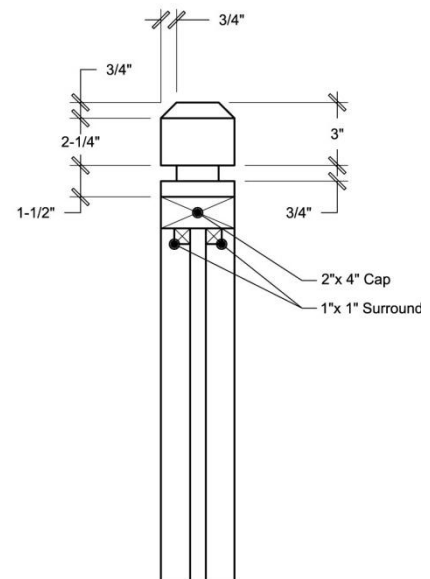
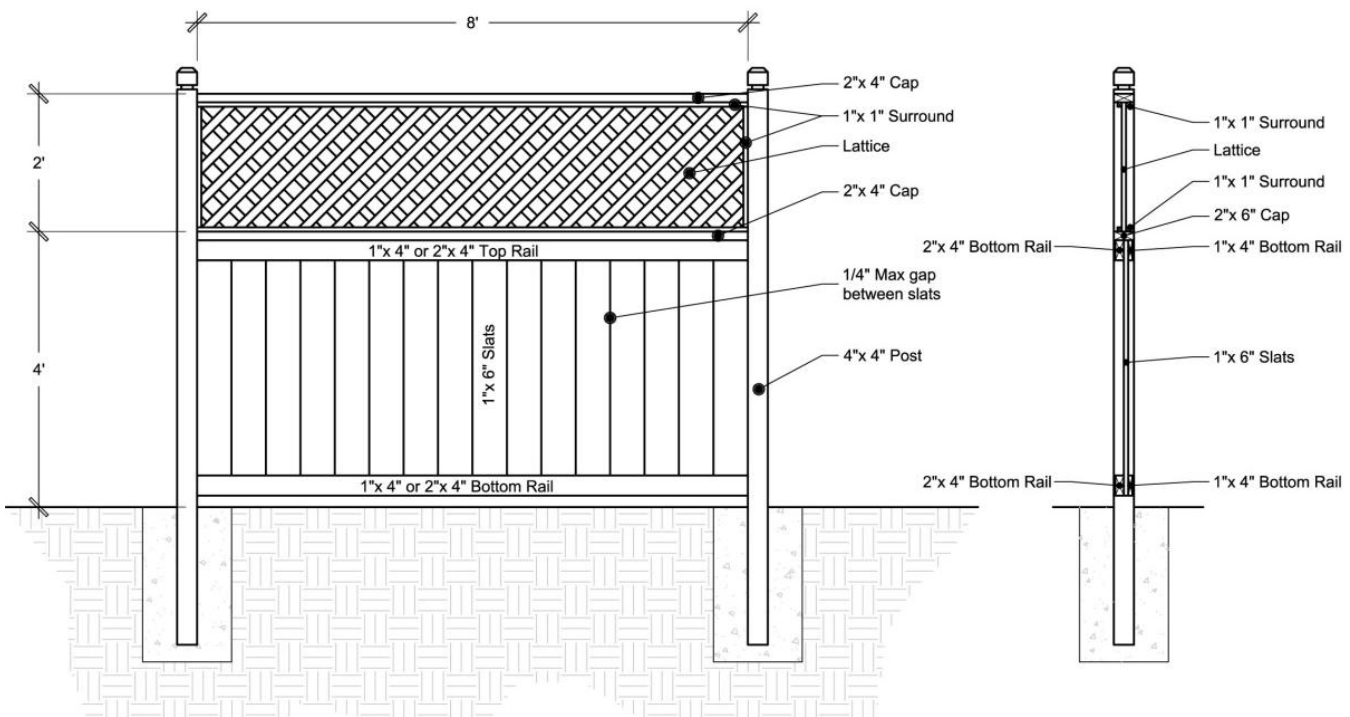

Alley Fence Option #2

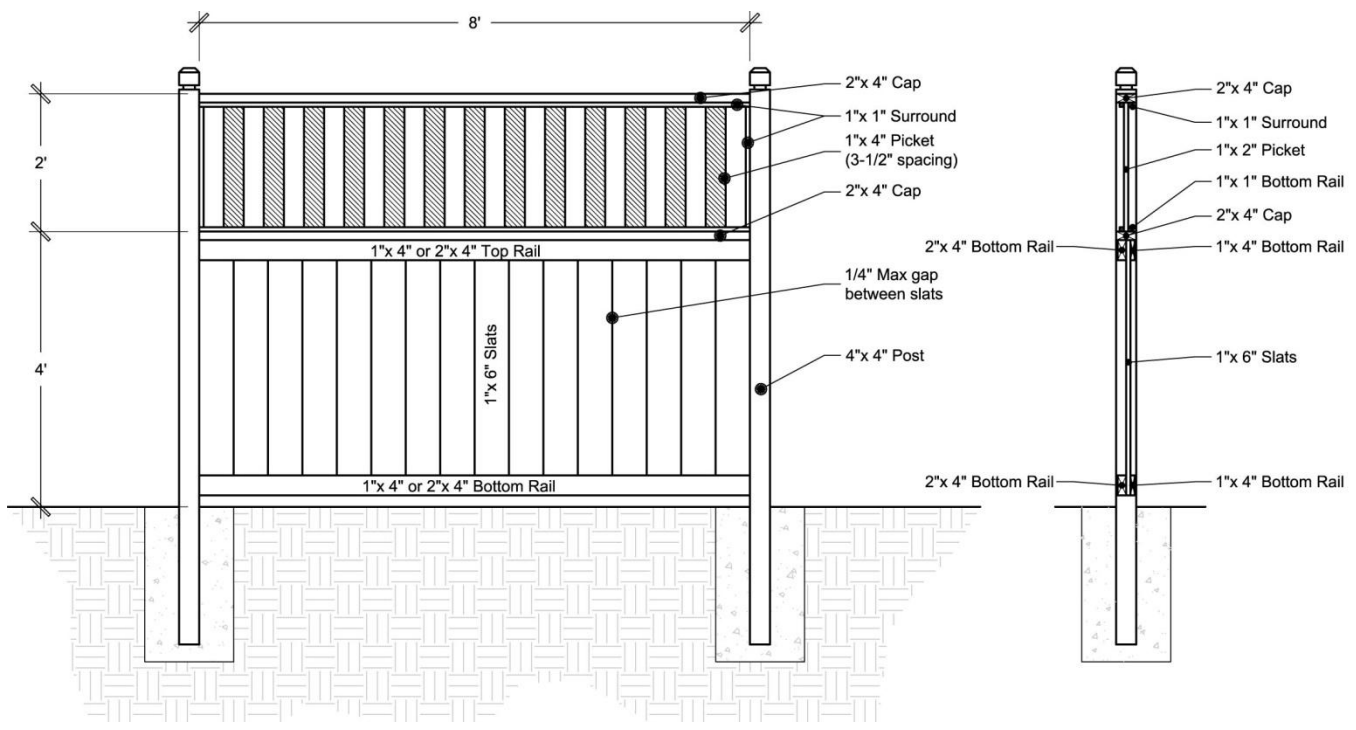

Alley Fence Option #3

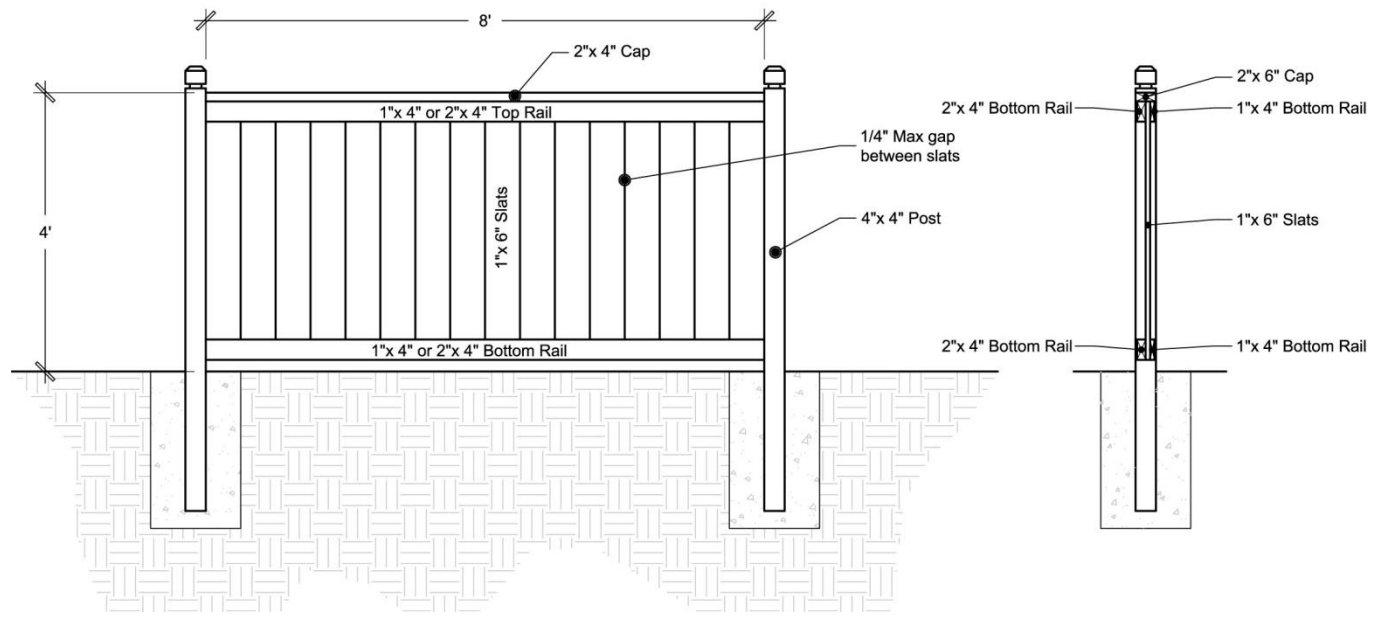

## 4. Corner Lot Fencing

### 4.1 Rear Yard backing Rear Yard

- Minimum 4' setback from the front corner of the house.
- Minimum 3' setback off the sidewalk that parallels the side property line. (City Required)
- Privacy fencing on corner lots is subject to "Line of Site" regulations implemented by Eagle Mountain City. Please contact the City Planning Department for more details. Eagle Mountain Code Section 17.60.140.

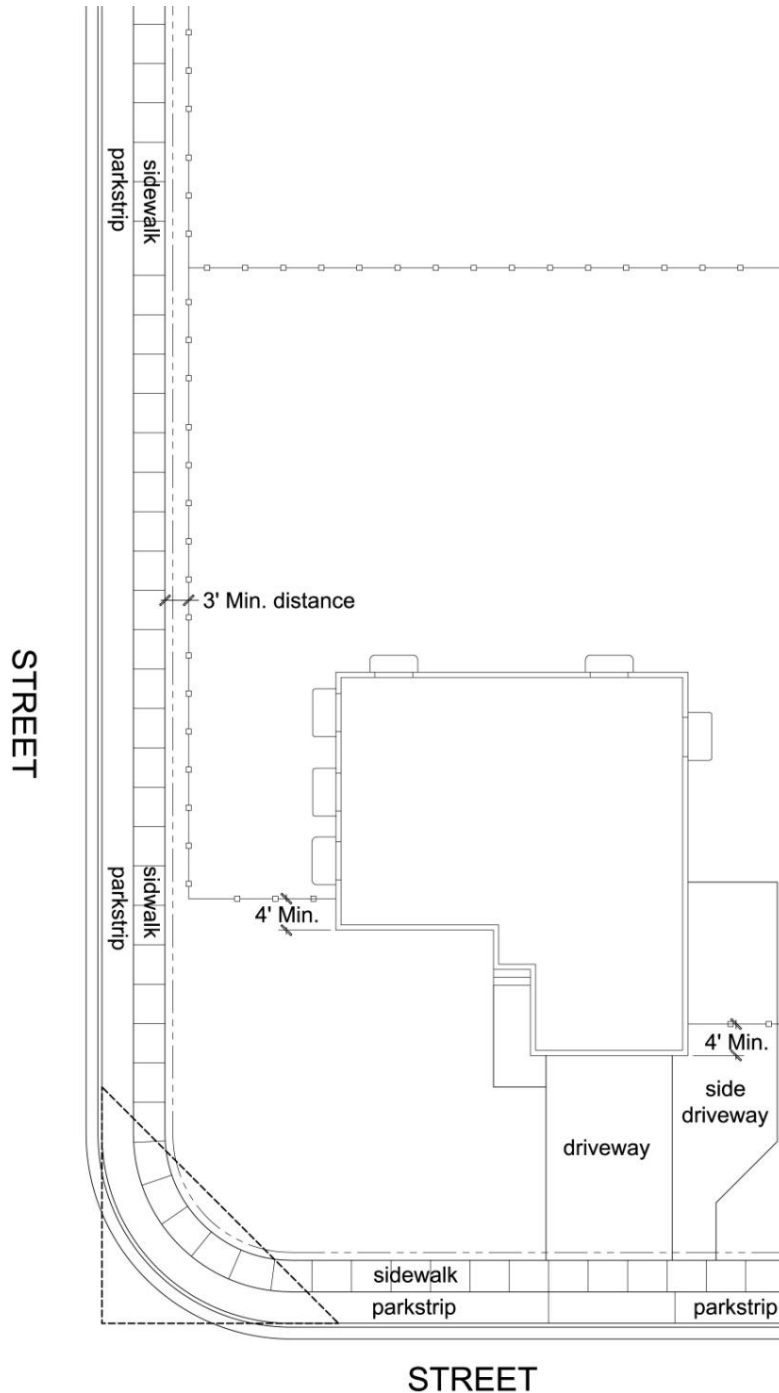

**4.2 Rear Yard backing Front Yard**

- Minimum 4' setback from the front corner of the house.
- Minimum 3' setback off the sidewalk that parallels the side property line. (City required)
- At a point of 15' from the rear property corner, make a 45° turn and continue at that 45° angle until it meets your rear property line (should be approximately 15 ft. from corner of property also). This 45° angle will not be considered front yard fencing for the home behind yours.
- Privacy fencing on corner lots is subject to "Line of Site" regulations implemented by Eagle Mountain City. Please contact the City Planning Department for more details. Eagle Mountain Code Section 17.60.140.

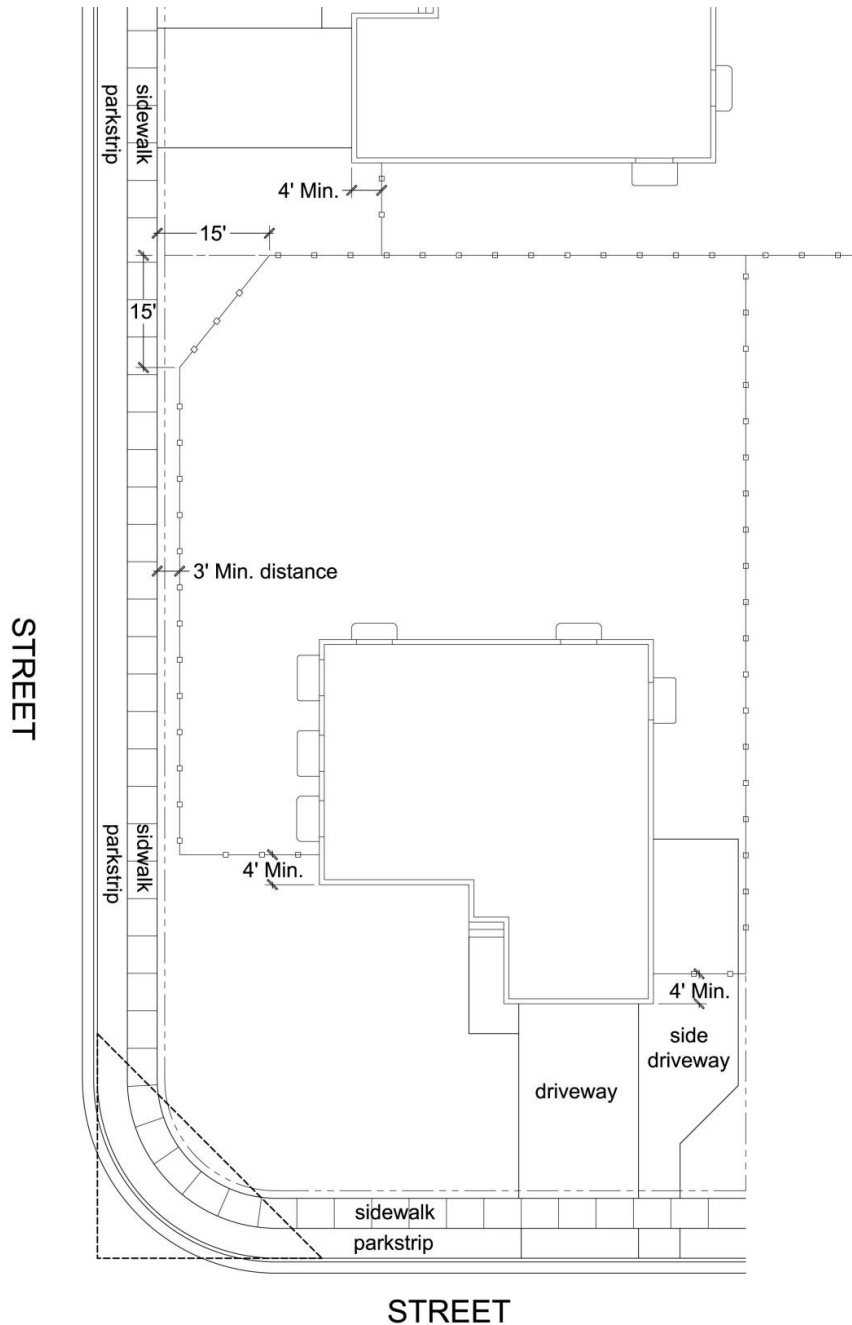

## 5. Open Space Fencing

- To be used whenever a fence parallels any public open space such as an equestrian trail, park, recreation trail, etc.
- Fence to be built with 6" x 6" cedar posts, 4' high using two 8" x 2" rails.
- Shall terminate at corners with a six-by-six inch wood post.

## 6. Trex Fencing

Trex Fencing is an approved fencing with the following guidelines;

- Only approved in the Winchester Grey color.
- Only the "Flat Cap" post top is approved.
- Posts must be set 30" in the ground, in concrete.
- Maximum fence height is 6'.
- Alleyways shall use the semi-private version (similar in design to Mini-Estates lattice top but with straight balusters rather than diagonal lattice in wood). Refer to illustration.



## Minimum Fence Style Allowed in Each Subdivision

Subdivision	Min. Fence Style
Ash Point	Entry
Castle Rock	Move Up/ <i>Estate</i>
Chimney Rock	Entry
Crittenden Corner	Move Up
Diamond Springs	Entry
Eagles Gate	Entry
Showdown at Eagle's Gate	Move Up
Eagle Top	Move Up
Freemont Springs	Entry
Friday Station	<i>Estate</i>
Hidden Canyon	Move Up
Highlands	Move Up
Highlands on the Green	Move Up
Jacobs Well	<i>Estate</i>
Kennekuk	<i>Estate</i>
Kiowa Valley	Entry
Liberty Farm	Entry
Lone Tree	Move Up
Mt. Airey	<i>Estate</i>
Northmoor	Move Up
O'Fallons Bluff A	<i>Estate</i>
O'Fallons Bluff D/E	Move Up
Point Lookout	<i>Estate</i>
Porters Crossing	Entry
Rockwell Village	<i>Estate</i>
Ruby Valley	Move Up
Rush Valley	Entry
Saddleback	Entry
Simpson Springs	<i>Estate</i>
Skyline Ridge	Move Up
Southmoor	Move Up
Stonebridge	<i>Estate</i>
Sundance	Entry
Sunrise at Kiowa	Move Up
Three Crossing	Entry

**Sloped Areas**

\*All fencing shall be stepped on sloped areas and shall not be used as a retaining wall for dirt and rock.

**STEPPED FENCING - PREFERRED**

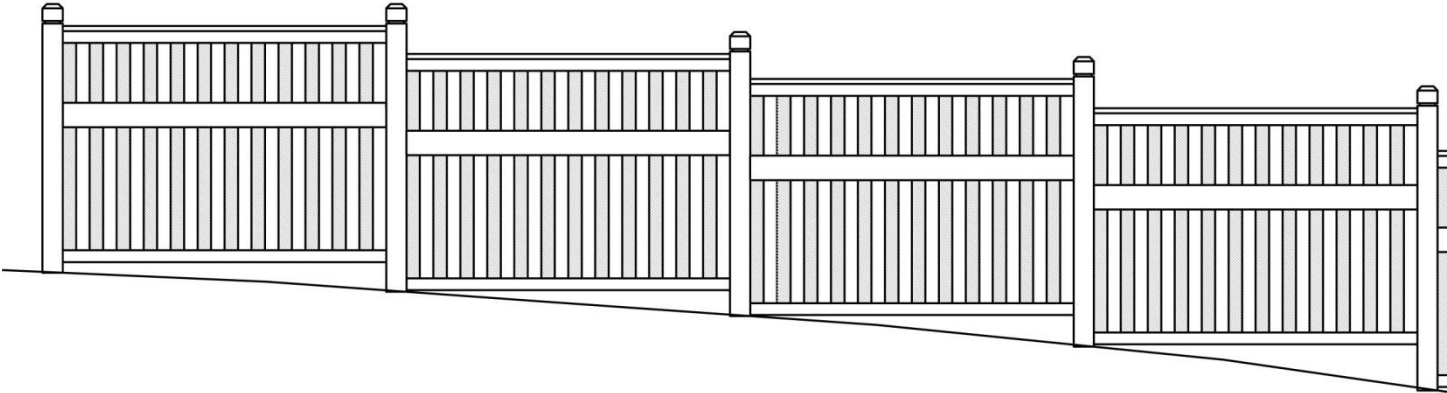

**SLOPED FENCING - NON-PREFERRED**

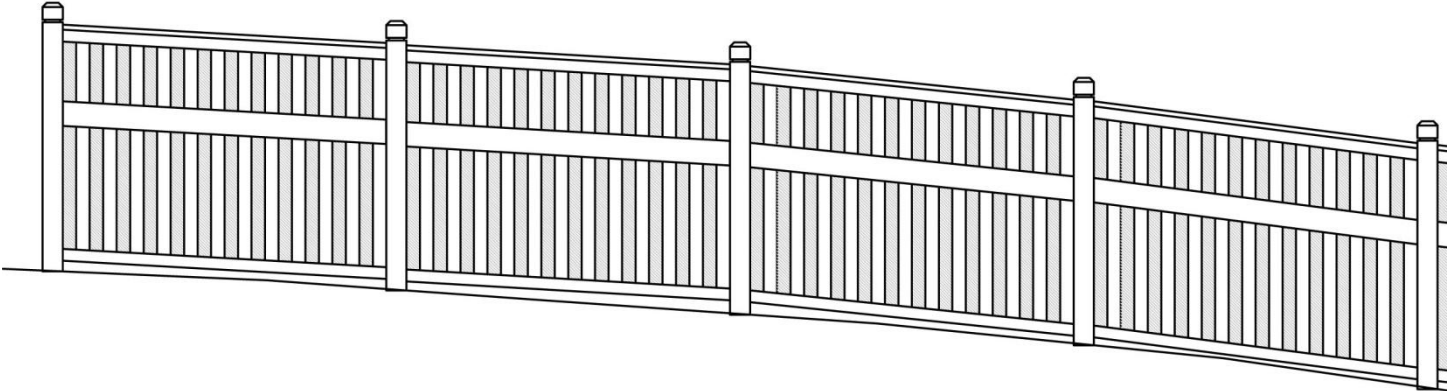

**Unacceptable Fencing**

- Following are a few examples of unacceptable fencing.



**Improper Design**



**No Top Railing, Dog-Eared Slats**



**No Rounded Tops**



**Correct, But No Stain**