

DESCRIPTION:

Slope construction with benches spaced at regular intervals perpendicular to the slope which intercept and collect sheet flow and direct it to a stable outfall point.

APPLICATION:

- ▶ Unstabilized cut and fill slopes
- ▶ Large stockpiles
- ▶ Existing unstable slopes

INSTALLATION/APPLICATION CRITERIA:

- ▶ Benches should be formed as slope is constructed and graded to the outlet point.
- ▶ Stabilized outlet with sediment controls should be in place prior to slope construction.

LIMITATIONS:

- ▶ Construction slope design must accommodate benching
- ▶ Not appropriate for sandy or rocky soil
- ▶ Only effective if suitable outlet provided

MAINTENANCE:

- ▶ Inspect after major storm events and at least biannually, repair any damaged areas
- ▶ Remove debris blocking water flow
- ▶ Inspect outlet, repair/replace sediment controls and remove sediment build up.

OBJECTIVES

- Housekeeping Practices
- Contain Waste
- Minimize Disturbed Areas
- Stabilize Disturbed Areas
- Protect Slopes/Channels
- Control Site Perimeter
- Control Internal Erosion

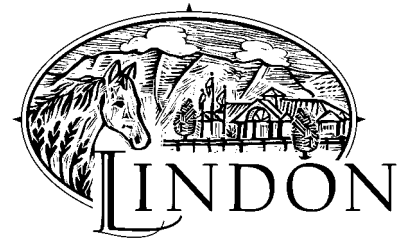

Adapted from Salt Lake County BMP Fact Sheet

TARGETED POLLUTANTS

- Sediment
- Nutrients
- Toxic Materials
- Oil & Grease
- Floatable Materials
- Other Waste

- High Impact
- Medium Impact
- Low or Unknown Impact

IMPLEMENTATION REQUIREMENTS

- Capital Costs
- O&M Costs
- Maintenance
- Training

- High
- Medium
- Low

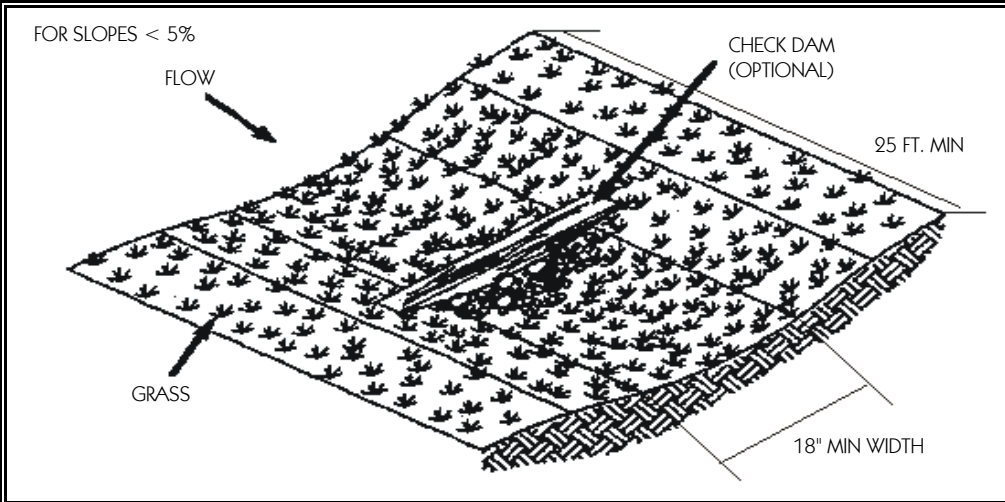

CONSIDERATIONS

- Soils
- Area Required
- Slope
- Water Availability
- Aesthetics
- Hydraulic Head
- Environmental Side Effects

DESCRIPTION:

Biofilters are of two general types: vegetated channel and vegetated filter strip. The vegetated channel is sloped like a standard storm drain channel; the storm water is treated as it passes through the channel. With filter strips the flow is distributed broadly along the width of the vegetated area.

APPLICATION:

- ▶ Comparable performance to wet ponds and constructed wetlands.
- ▶ Limited to treating a few acres.

INSTALLATION/APPLICATION CRITERIA:

- ▶ The surface area must be defined.
- ▶ The minimum width for a swale is determined by Mannings Equation.
- ▶ Minimum length of a strip is 10 feet.
- ▶ The longitudinal slope must not exceed 5%.
- ▶ Use a flow spreader and energy dissipater at the entrance of a swale.
- ▶ Good soils are important to achieve good vegetation cover.

LIMITATIONS:

- ▶ Good performance depends upon good design
- ▶ May be limited to areas where summer irrigation is feasible.
- ▶ Can be difficult to maintain sheet flow in strips.
- ▶ Can be difficult to avoid channelization in swales.
- ▶ Cannot be placed on steep slope.
- ▶ Area required may make infeasible on industrial sites.
- ▶ Proper maintenance required to maintain health and density of vegetation.
- ▶ Limited to treating a few acres and availability of water during dry season.

MAINTENANCE:

- ▶ Make sure soils are suitable for healthy vegetation.
- ▶ Level cross-section and even longitudinal slope for swales.
- ▶ Any damage to the channel such as rutting must be repaired with suitable soil, properly tamped and seeded.

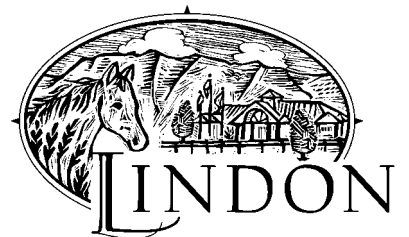

Adapted from Salt Lake County BMP Fact Sheet

TARGETED POLLUTANTS

- Sediment
- Nutrients
- Heavy Metals
- Toxic Materials
- Oxygen Demanding Substances
- Oil & Grease
- Floatable Materials
- Bacteria & Viruses

- High Impact
- Medium Impact
- Low or Unknown Impact

IMPLEMENTATION REQUIREMENTS

- Capital Costs
- O&M Costs
- Maintenance
- Training

- High Medium Low

BMP: BMP Inspection and Maintenance

BMPIM



APPLICATIONS

- Manufacturing
- Material Handling
- Vehicle Maintenance
- Construction
- Commercial Activities
- Roadways
- Waste Containment
- Housekeeping Practices

DESCRIPTION:

Inspect and maintain all structural BMP's (both existing and new) on a routine basis to remove pollutants from entering storm drain inlets. This includes the establishment of a schedule for inspections and maintenance.

APPROACH:

Regular maintenance of all structural BMP's is necessary to ensure their proper functionality.

- Annual inspections.
- Prioritize maintenance to clean, maintain, and repair or replace structures in areas beginning with the highest pollutant loading.
- Clean structural BMP's in high pollutant areas just before the wet season to remove sediments and debris accumulated during the summer and fall.
- Keep accurate logs of what structures were maintained and when they were maintained.
- Record the amount of waste collected.

LIMITATIONS:

- Availability of trained staff

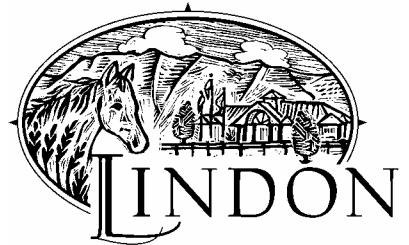

TARGETED POLLUTANTS

- Sediment
- Nutrients
- Heavy Metals
- Toxic Materials
- Oxygen Demanding Substances
- Oil & Grease
- Floatable Materials
- Bacteria & Viruses

- High Impact
- Medium Impact
- Low or Unknown Impact

IMPLEMENTATION REQUIREMENTS

- Capital Costs
- O&M Costs
- Maintenance
- Staffing
- Training
- Administrative

- High Medium Low

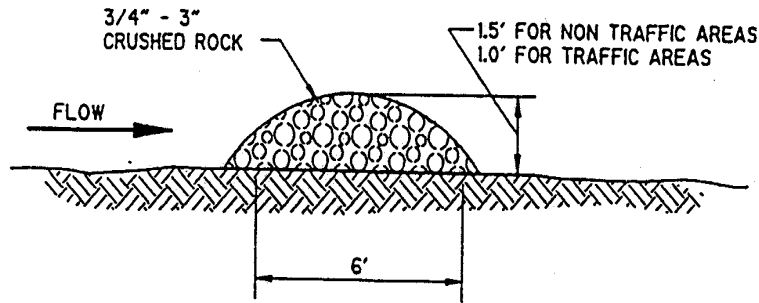

DESCRIPTION:

A rock filter is made of rock 3/4 - 3" in diameter and placed along a level contour. A brush filter is composed of brush (usually obtained during the site clearing) wrapped in filter cloth and anchored to the toe of the slope. If properly anchored brush or rock filters may be used for sediment trapping and velocity reduction.

APPLICATION:

- ▶ As check dams across mildly sloped construction roads.
- ▶ Below the toe of slopes.
- ▶ Along the site perimeter.
- ▶ In areas where sheet or rill flow occurs.
- ▶ Around temporary spoil areas.
- ▶ At sediment traps or culvert/pipe outlets.

INSTALLATION/APPLICATION CRITERIA:

- ▶ For rock filter, use larger rock and place in a staked, woven wire sheathing if placed where concentrated flows occur.
- ▶ Install along a level contour.
- ▶ Leave area behind berm where runoff can pond and sediment can settle.
- ▶ Drainage areas should not exceed 5 acres.

LIMITATIONS:

- ▶ Rock berms may be difficult to remove.
- ▶ Removal problems limit their usefulness in landscaped areas.
- ▶ Runoff will pond upstream of the filter, possibly causing flooding if sufficient space does not exist.

MAINTENANCE:

- ▶ Inspect monthly after each rainfall.
- ▶ If berm is damaged, reshape and replace lost/dislodged rock.
- ▶ Remove sediment when depth reaches 1/3 of berm height, or 1 ft.

OBJECTIVES

- Housekeeping Practices
- Contain Waste
- Minimize Disturbed Areas
- Stabilize Disturbed Areas
- Protect Slopes/Channels
- Control Site Perimeter
- Control Internal Erosion



Adapted from Salt Lake County BMP Fact Sheet

TARGETED POLLUTANTS

- Sediment
- Nutrients
- Toxic Materials
- Oil & Grease
- Floatable Materials
- Other Waste

- High Impact
- Medium Impact
- Low or Unknown Impact

IMPLEMENTATION REQUIREMENTS

- Capital Costs
- O&M Costs
- Maintenance
- Training

- High
- Medium
- Low

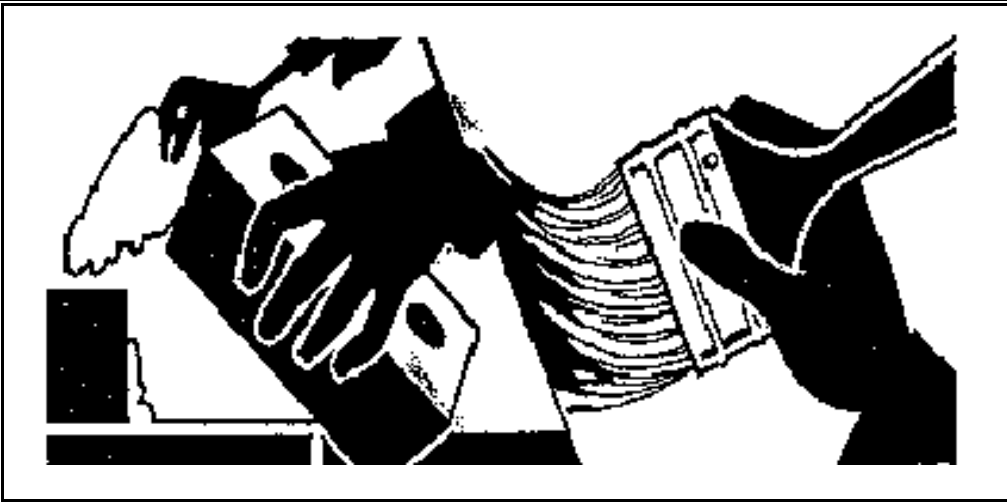

DESCRIPTION:

Prevent or reduce the discharge of pollutants to storm water from building repair, remodeling and construction by using soil erosion controls, enclosing or covering building material storage areas, using good housekeeping practices, using safer alternative products, and training employees.

APPLICATION:

- ▶ Use soil erosion control techniques if bare ground is temporarily exposed.
- ▶ Use permanent soil erosion control techniques if the remodeling clears buildings from an area that is not to be replaced.

INSTALLATION/APPLICATION CRITERIA:

- ▶ Enclose painting operations consistent with local air quality regulations and OSHA.
- ▶ Properly store materials that are normally used in repair and remodeling such as paints and solvents.
- ▶ Properly store and dispose of waste materials generated from the activity.
- ▶ Maintain good housekeeping practices while work is underway.

LIMITATIONS:

- ▶ This BMP is for minor construction only.
- ▶ Hazardous waste that cannot be re-used or recycled must be disposed of by a licensed hazardous waste hauler.
- ▶ Safer alternative products may not be available, suitable, or effective in every case.
- ▶ Be certain that actions to help storm water quality are consistent with OSHA and air quality regulations.

MAINTENANCE:

None.

OBJECTIVES

- Housekeeping Practices
- Contain Waste
- Minimize Disturbed Areas
- Stabilize Disturbed Areas
- Protect Slopes/Channels
- Control Site Perimeter
- Control Internal Erosion

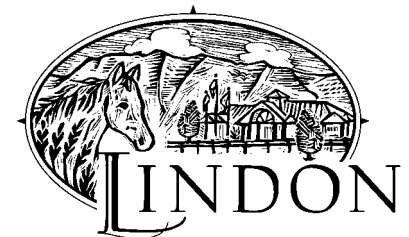

Adapted from Salt Lake County BMP Fact Sheet

TARGETED POLLUTANTS

- Sediment
- Nutrients
- Toxic Materials
- Oil & Grease
- Floatable Materials
- Other Waste

- High Impact
- Medium Impact
- Low or Unknown Impact

IMPLEMENTATION REQUIREMENTS

- Capital Costs
- O&M Costs
- Maintenance
- Training

- High
- Medium
- Low

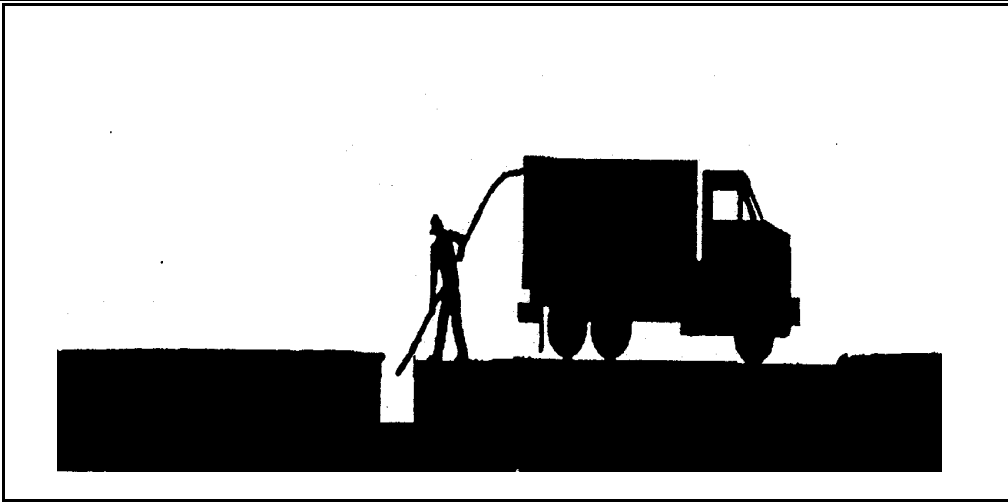

DESCRIPTION:

Maintain catch basin and stormwater inlets on a regular basis to remove pollutants, reduce high pollutant concentrations during the first flush of storms, prevent clogging of the downstream conveyance system, and restore the catch basins' sediment trapping capacity. A catch basin is distinguished from a stormwater inlet by having at its base a sediment sump designed to catch and retain sediments below the overflow point. This information sheet focuses on the cleaning of accumulated sediments from catch basins.

APPROACH:

Regular maintenance of catch basins and inlets is necessary to ensure their proper functioning. Clogged catch basins are not only useless but may act as a source of sediments and pollutants. In general, the key to effective catch basins are:

- ▶ At least annual inspections.
- ▶ Prioritize maintenance to clean catch basins and inlets in areas with the highest pollutant loading.
- ▶ Clean catch basins in high pollutant load areas just before the wet season to remove sediments and debris accumulated during the summer.
- ▶ Keep accurate logs of the number of catch basins cleaned.
- ▶ Record the amount of waste collected.

LIMITATIONS:

There are no major limitations to this best management practice.

MAINTENANCE:

Regular maintenance of public and private catch basins and inlets is necessary to ensure their proper functioning. Clogged catch basins are not only useless but may act as a source of sediments and pollutants. In general, the keys to effective catch basins are:

- ▶ Annual/monthly inspection of public and private facilities to ensure structural integrity, a clean sump, and a stenciling of catch basins and inlets.
- ▶ Keep logs of the number of catch basins cleaned.
- ▶ Record the amount of waste collected.

PROGRAM ELEMENTS

- New Development
- Residential
- Commercial Activities
- Industrial Activities
- Municipal Facilities
- Illegal Discharges

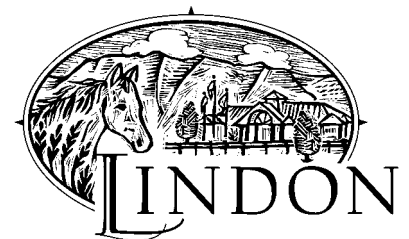

Adapted from Salt Lake County BMP Fact Sheet

TARGETED POLLUTANTS

- Sediment
- Nutrients
- Heavy Metals
- Toxic Materials
- Oxygen Demanding Substances
- Oil & Grease
- Floatable Materials
- Bacteria & Viruses

- High Impact
- Medium Impact
- Low or Unknown Impact

IMPLEMENTATION REQUIREMENTS

- Capital Costs
- O&M Costs
- Regulatory
- Training
- Staffing
- Administrative

- High
- Medium
- Low



OBJECTIVES

- Housekeeping Practices
- Contain Waste
- Minimize Disturbed Areas
- Stabilize Disturbed Areas
- Protect Slopes/Channels
- Control Site Perimeter
- Control Internal Erosion



Adapted from Salt Lake County BMP Fact Sheet

DESCRIPTION:

Prevent or reduce the discharge of pollutants to storm water from contaminated or erodible surface areas by leaving as much vegetation on-site as possible, minimizing soil exposure time, stabilizing exposed soils, and preventing storm water runoff and runoff.

APPLICATION:

This BMP addresses soils which are not so contaminated as to exceed criteria but the soil is eroding and carrying pollutants off in the storm water.

INSTALLATION/APPLICATION CRITERIA:

Contaminated or erodible surface areas can be controlled by:

- ▶ Preservation of natural vegetation
- ▶ Re-vegetation
- ▶ Chemical stabilization
- ▶ Removal of contaminated soils
- ▶ Geosynthetics.

LIMITATIONS:

Disadvantages of preserving natural vegetation or re-vegetating include:

- ▶ Requires substantial planning to preserve and maintain the existing vegetation.
- ▶ May not be cost-effective with high land costs.
- ▶ Lack of rainfall and/or poor soils may limit the success of re-vegetated areas.

Disadvantages of chemical stabilization include:

- ▶ Creation of impervious surfaces.
- ▶ May cause harmful effects on water quality.
- ▶ Is usually more expensive than vegetative cover.

MAINTENANCE:

Maintenance should be minimal, except possibly if irrigation of vegetation is necessary.

TARGETED POLLUTANTS

- Sediment
- Nutrients
- Toxic Materials
- Oil & Grease
- Floatable Materials
- Other Waste

- High Impact
- Medium Impact
- Low or Unknown Impact

IMPLEMENTATION REQUIREMENTS

- Capital Costs
- O&M Costs
- Maintenance
- Training

- High
- Medium
- Low

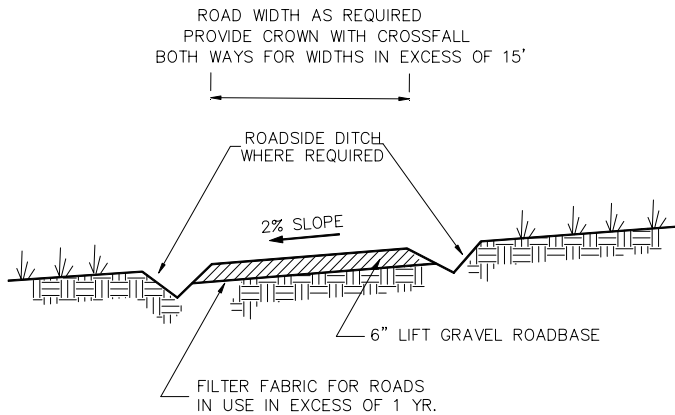

OBJECTIVES

- Housekeeping Practices
- Contain Waste
- Minimize Disturbed Areas
- Stabilize Disturbed Areas
- Protect Slopes/Channels
- Control Site Perimeter
- Control Internal Erosion



Adapted from Salt Lake County BMP Fact Sheet

DESCRIPTION:

Temporary stabilization of on-site roadway by placement of gravel roadbase.

APPLICATION:

- ▶ On-site roadways used daily by construction traffic (may not apply to gravelly type soils)
- ▶ Parking or staging areas susceptible to erosion due to traffic use

INSTALLATION/APPLICATION CRITERIA:

- ▶ Grade temporary access road with 2% cross fall, for two-way width provide crown.
- ▶ Provide roadside ditch and outlet controls where required.
- ▶ Place 6 inches of 2-inch to 4-inch crushed rock on driving area

LIMITATIONS:

- ▶ May require removal of gravel roadbase at completion of activities if final cover is not impervious
- ▶ May require controls for surface storm water runoff

MAINTENANCE:

- ▶ Inspect after major rainfall events and at least monthly.
- ▶ Place additional gravel as needed and repair any damaged areas.
- ▶ Maintain any roadside drainage controls.

TARGETED POLLUTANTS

- Sediment
- Nutrients
- Toxic Materials
- Oil & Grease
- Floatable Materials
- Other Waste

- High Impact
- Medium Impact
- Low or Unknown Impact

IMPLEMENTATION REQUIREMENTS

- Capital Costs
- O&M Costs
- Maintenance
- Training

- High
- Medium
- Low



In sequenced construction, sites are completed in stages and completed portions are permanently stabilized before other areas are disturbed

DESCRIPTION:

Construction sequencing requires creating and following a work schedule that balances the timing of land disturbance activities and the installation of measures to control erosion and sedimentation, in order to reduce on-site erosion and off-site sedimentation. Staging areas can be used to limit contamination and erosion.

APPROACH:

Construction sequencing can be used to plan earthwork and erosion and sediment control (ESC) activities at sites where land disturbances might affect water quality in a receiving water body.

Construction sequencing schedules should, at a minimum, include the following:

- The ESC practices that are to be installed
- Principal development activities
- Which measures should be installed before other activities are started
- Compatibility with the general contract construction schedule

The following activities and features should be included (as they apply):

- Construction access—entrance to site, construction routes, areas designated for equipment parking
- Sediment traps and barriers—basin traps, sediment fences, outlet protection
- Runoff conveyance system—stabilize stream banks, storm drains, channels, inlet and outlet protection, slope drains
- Land clearing and grading—site preparation (cutting, filling, and grading, sediment traps, barriers, diversions, drains, surface roughening)
- Landscaping and final stabilization—top-soiling, trees and shrubs, permanent seeding, mulching, sodding, riprap

LIMITATIONS:

- Weather and other unpredictable variables may affect construction sequence schedules.

MAINTENANCE:

- The construction sequence should be followed throughout the project and the written plan should be modified before any changes in construction activities are executed.

APPLICATIONS

- Manufacturing
- Material Handling
- Vehicle Maintenance
- Construction
- Commercial Activities
- Roadways
- Waste Containment
- Housekeeping Practices

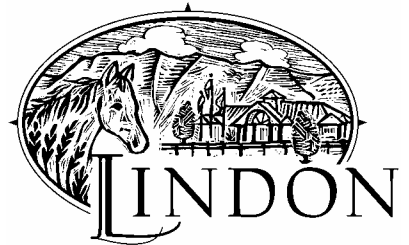

TARGETED POLLUTANTS

- Sediment
- Nutrients
- Heavy Metals
- Toxic Materials
- Oxygen Demanding Substances
- Oil & Grease
- Floatable Materials
- Bacteria & Viruses

- High Impact
- Medium Impact
- Low or Unknown Impact

IMPLEMENTATION REQUIREMENTS

- Capital Costs
- O&M Costs
- Maintenance
- Training

- High
- Medium
- Low

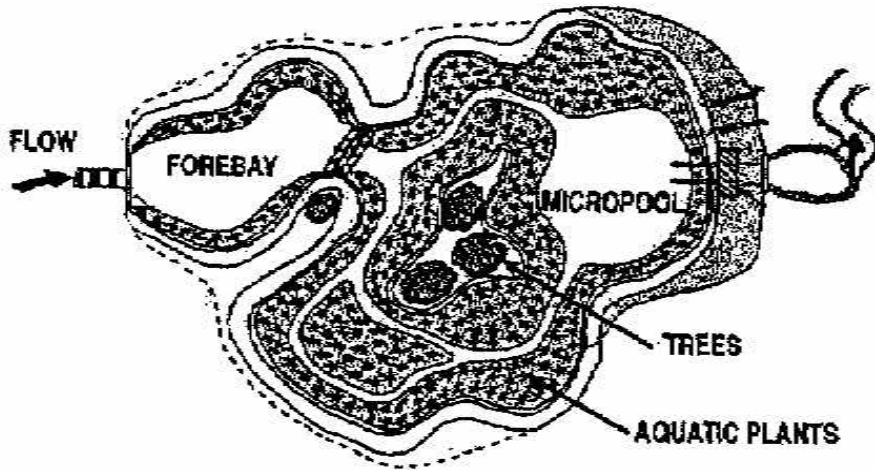

CONSIDERATIONS

- Soils
- Area Required
- Slope
- Water Availability
- Aesthetics
- Hydraulic Head
- Environmental Side Effects

DESCRIPTION:

Constructed wetlands have a significant percentage of the facility covered by wetland vegetation.

APPLICATION:

- ▶ Need to achieve high level of particulate and some dissolved contaminant removal.
- ▶ Ideal for large, regional tributary areas.
- ▶ Multiple benefits of passive recreation and wildlife.

INSTALLATION/APPLICATION CRITERIA:

- ▶ Suitable soils for wetland vegetation are required.
- ▶ Surface area equal to at least 1% and preferably 2% of the tributary watershed.
- ▶ Include a forebay for extra storage and to trap incoming sediment.
- ▶ Involve qualified wetland ecologist to design and install wetland vegetation.
- ▶ Establishing wetland vegetation may be difficult.

LIMITATIONS:

- ▶ Concern for mosquitoes.
- ▶ Cannot be placed on steep unstable slopes.
- ▶ Need base flow to maintain water level.
- ▶ Not feasible in densely developed areas.
- ▶ Nutrient release may occur during winter.
- ▶ Overgrowth can lead to reduced hydraulic capacity.
- ▶ Regulatory agencies may limit water quality to constructed wetlands.

MAINTENANCE:

- ▶ Remove foreign debris and sediment build-up.
- ▶ Areas of bank erosion should be repaired.
- ▶ Remove nuisance species.
- ▶ Control mosquitoes.



Adapted from Salt Lake County BMP Fact Sheet

TARGETED POLLUTANTS

- Sediment
- Nutrients
- Heavy Metals
- Toxic Materials
- Oxygen Demanding Substances
- Oil & Grease
- Floatable Materials
- Bacteria & Viruses

- High Impact
- Medium Impact
- Low or Unknown Impact

IMPLEMENTATION REQUIREMENTS

- Capital Costs
- O&M Costs
- Maintenance
- Training

- High Medium Low

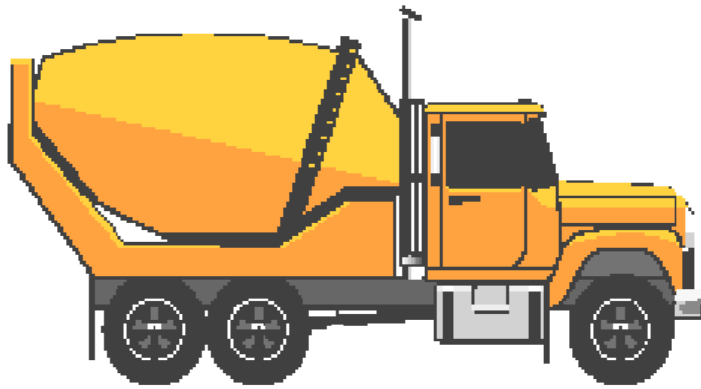

OBJECTIVES

- Housekeeping Practices
- Contain Waste
- Minimize Disturbed Areas
- Stabilize Disturbed Areas
- Protect Slopes/Channels
- Control Site Perimeter
- Control Internal Erosion



Adapted from Salt Lake County BMP Fact Sheet

DESCRIPTION:

Prevent or reduce the discharge of pollutants to storm water from concrete waste by conducting washout off-site, performing on-site washout in a designated area, and training employees and subcontractors.

APPLICATIONS:

This technique is applicable to all types of sites.

INSTALLATION/APPLICATION CRITERIA:

- ▶ Store dry and wet materials under cover, away from drainage areas.
- ▶ Avoid mixing excess amounts of fresh concrete or cement on-site.
- ▶ Perform washout of concrete trucks off-site or in designated areas only.
- ▶ Do not wash out concrete trucks into storm drains, open ditches, streets, or streams.
- ▶ Do not allow excess concrete to be dumped on-site, except in designated areas.
- ▶ When washing concrete to remove fine particles and expose the aggregate, avoid creating runoff by draining the water within a bermed or level area. (See Earth Berm Barrier information sheet.)
- ▶ Train employees and subcontractors in proper concrete waste management.

LIMITATIONS:

- ▶ Off-site washout of concrete wastes may not always be possible.

MAINTENANCE:

- ▶ Inspect subcontractors to ensure that concrete wastes are being properly managed.
- ▶ If using a temporary pit, dispose hardened concrete on a regular basis.

TARGETED POLLUTANTS

- Sediment
- Nutrients
- Toxic Materials
- Oil & Grease
- Floatable Materials
- Other Waste

- High Impact
- Medium Impact
- Low or Unknown Impact

IMPLEMENTATION REQUIREMENTS

- Capital Costs
- O&M Costs
- Maintenance
- Training

- High
- Medium
- Low

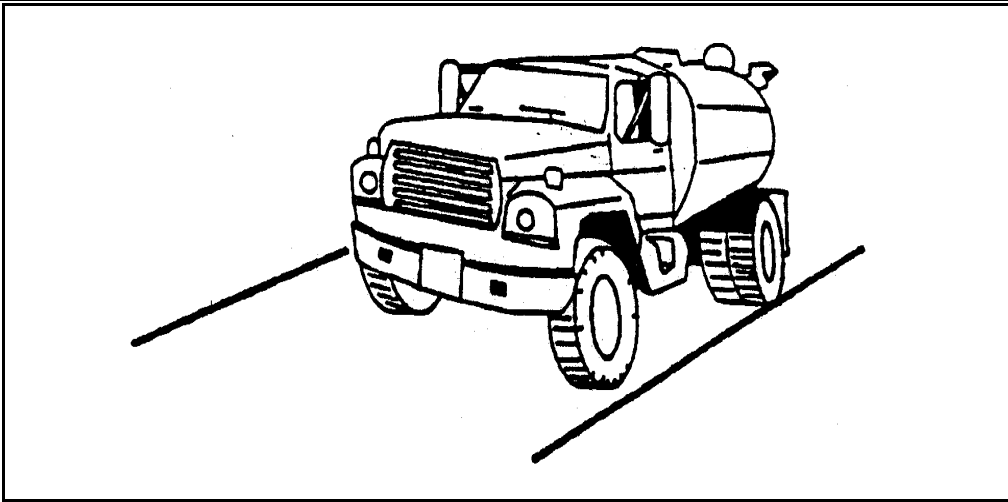

DESCRIPTION:

Dust control measures are used to stabilize soil from wind erosion, and reduce dust by construction activities.

APPLICATION:

Dust control is useful in any process area, loading and unloading area, material handling areas, and transfer areas where dust is generated. Street sweeping is limited to areas that are paved.

INSTALLATION/APPLICATION CRITERIA:

- ▶ Two kinds of street sweepers are common: brush and vacuum. Vacuum sweepers are more efficient and work best when the area is dry.
- ▶ Mechanical equipment should be operated according to the manufacturers' recommendations and should be inspected regularly.
- ▶ Water may be sprayed on the ground surface to moisten dry soils, making it less susceptible to wind erosion.

LIMITATIONS:

- ▶ Street sweeping is labor and equipment intensive and may not be effective for all pollutants.
- ▶ Water sprayed from water trucks must be done at a rate such that the water is absorbed in the soil; if excessive amounts of water are used, it may run off, carrying soil with it.

MAINTENANCE:

If excess water results from water spraying, dust-contaminated waters should not be allowed to run off site. Areas may need to be resprayed to keep dust from spreading.

OBJECTIVES

- Housekeeping Practices
- Contain Waste
- Minimize Disturbed Areas
- Stabilize Disturbed Areas
- Protect Slopes/Channels
- Control Site Perimeter
- Control Internal Erosion



Adapted from Salt Lake County BMP Fact Sheet

TARGETED POLLUTANTS

- Sediment
- Nutrients
- Toxic Materials
- Oil & Grease
- Floatable Materials
- Other Waste

- High Impact
- Medium Impact
- Low or Unknown Impact

IMPLEMENTATION REQUIREMENTS

- Capital Costs
- O&M Costs
- Maintenance
- Training

- High
- Medium
- Low

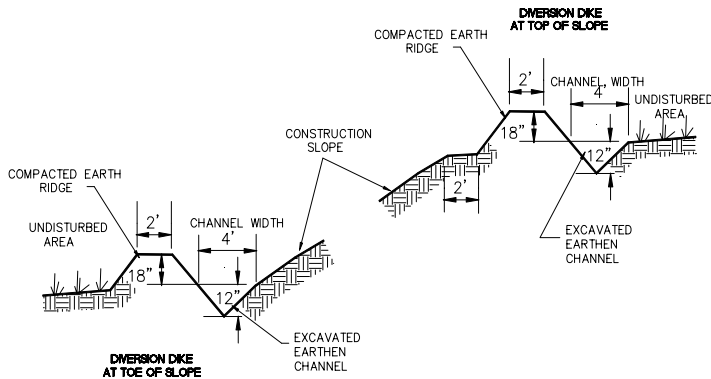

OBJECTIVES

- Housekeeping Practices
- Contain Waste
- Minimize Disturbed Areas
- Stabilize Disturbed Areas
- Protect Slopes/Channels
- Control Site Perimeter
- Control Internal Erosion

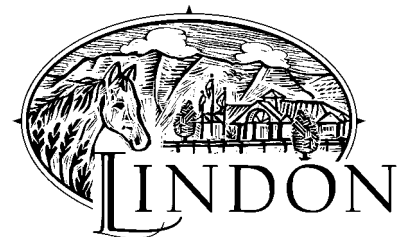

Adapted from Salt Lake County BMP Fact Sheet

DESCRIPTION:

A temporary sediment barrier and storm runoff conveyance consisting of an excavation channel and compacted earth ridge.

APPLICATION:

- ▶ Construct along top of construction slope to intercept upgradient runoff and convey around construction site.
- ▶ Construct along toe of construction to divert sediment laden runoff.
- ▶ Construct along midpoint of construction slope to intercept runoff and channel to controlled discharge point.
- ▶ Construct around base of soil stockpiles to capture sediment.
- ▶ Construct around perimeter of disturbed areas to capture sediment.

INSTALLATION/APPLICATION CRITERIA:

- ▶ Clear and grub area for dike construction.
- ▶ Excavate channel and place soil on downgradient side.
- ▶ Shape and machine compact excavated soil to form ridge.
- ▶ Place erosion protection (riprap, mulch) at outlet.
- ▶ Stabilize channel and ridge as required with mulch, gravel, or vegetative cover.

LIMITATIONS:

- ▶ Recommended maximum drainage area of 5 acres
- ▶ Recommended maximum sideslopes of 2h:1v (50%)
- ▶ Recommended maximum slope on channel of 1%

MAINTENANCE:

- ▶ Inspect immediately after any rainfall and at least daily during prolonged rainfall.
- ▶ Look for runoff breaching dike or eroding channel or sideslopes.
- ▶ Check discharge point for erosion or bypassing of flows.
- ▶ Repair and stabilize as necessary.
- ▶ Inspect daily during vehicular activity on slope, check for and repair any traffic damage.

TARGETED POLLUTANTS

- Sediment
- Nutrients
- Toxic Materials
- Oil & Grease
- Floatable Materials
- Other Waste

- High Impact
- Medium Impact
- Low or Unknown Impact

IMPLEMENTATION REQUIREMENTS

- Capital Costs
- O&M Costs
- Maintenance
- Training

- High
- Medium
- Low

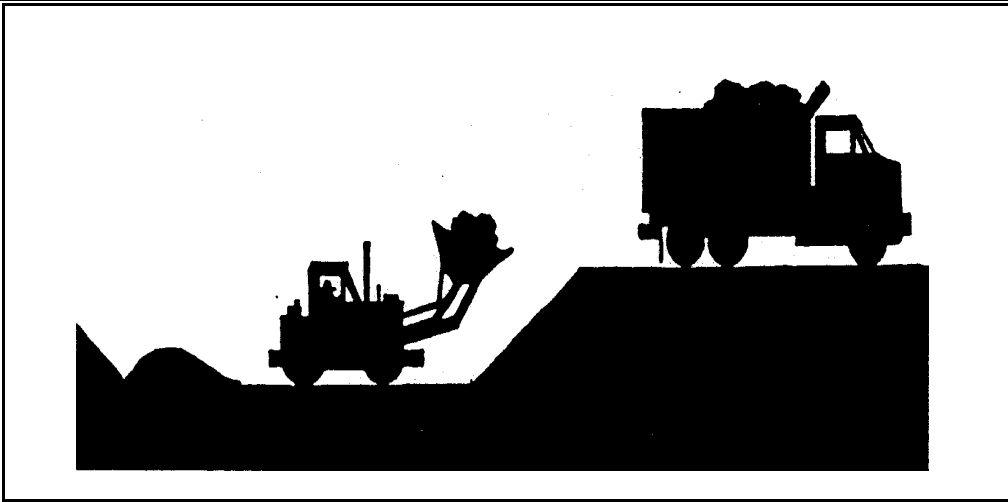

DESCRIPTION:

Proper maintenance and siltation removal is required on both a routine and corrective basis to promote effective storm water pollutant removal efficiencies for wet/dry detention pond and infiltrative devices.

APPROACH:

- ▶ Remove silt after sufficient accumulation.
- ▶ Periodically clean accumulated sediment and silt out of pre-treatment inlets.
- ▶ Infiltration device silt removal should occur when the infiltration rate drops below ½ inch per hour.
- ▶ Removal of accumulated paper, trash, and debris should occur every six months or as needed to prevent clogging of control devices.
- ▶ Vegetation growth should not be allowed to exceed 18 inches in height.
- ▶ Mow the slopes periodically and check for clogging, erosion and tree growth on the embankment.
- ▶ Corrective maintenance may require more frequent attention (as required).
- ▶ Create a public education campaign to explain the function of wet/dry detention pond/infiltration devices and their operation requirements for proper effectiveness.
- ▶ Encourage the public to report wet/dry detention pond/infiltration devices needing maintenance.

LIMITATIONS:

- ▶ Wet detention pond dredging can produce slurried waste that often exceeds the requirements of many landfills.
- ▶ Frequent sediment removal is labor and cost intensive.

PROGRAM ELEMENTS

- New Development
- Residential
- Commercial Activities
- Industrial Activities
- Municipal Facilities
- Illegal Discharges

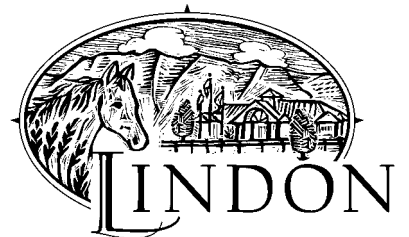

Adapted from Salt Lake County BMP Fact Sheet

TARGETED POLLUTANTS

- Sediment
- Nutrients
- Heavy Metals
- Toxic Materials
- Oxygen Demanding Substances
- Oil & Grease
- Floatable Materials
- Bacteria & Viruses

- High Impact
- Medium Impact
- Low or Unknown Impact

IMPLEMENTATION REQUIREMENTS

- Capital Costs
- O&M Costs
- Regulatory
- Training
- Staffing
- Administrative

- High Medium Low

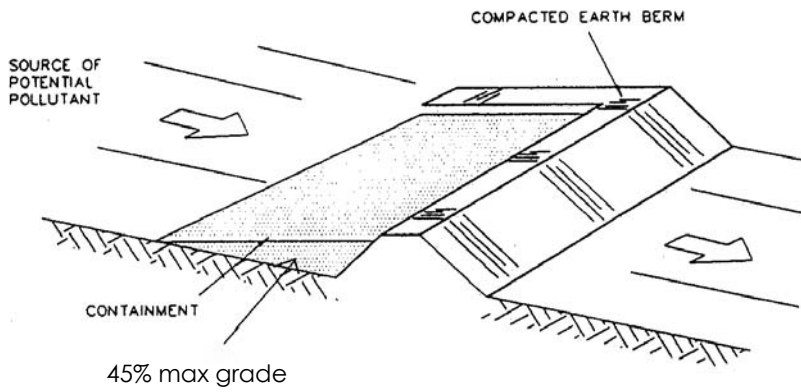

OBJECTIVES

- Housekeeping Practices
- Contain Waste
- Minimize Disturbed Areas
- Stabilize Disturbed Areas
- Protect Slopes/Channels
- Control Site Perimeter
- Control Internal Erosion

DESCRIPTION:

A temporary containment control constructed of compacted soil.

APPLICATION:

- ▶ Construct around waste and materials storage area.
- ▶ Construct around staging and maintenance areas.
- ▶ Construct around vehicle parking and servicing areas.

INSTALLATION/APPLICATION CRITERIA:

- ▶ Construct an earthen berm down hill of the area to be controlled. The berm should surround fueling facilities and maintenance areas on three sides to provide containment.
- ▶ Berm needs to be a minimum of 1 foot tall by 1 foot wide and be compacted by earth moving equipment.

LIMITATIONS:

- ▶ Not effective on steep slopes.
- ▶ Limits access to controlled area.
- ▶ Personnel need to quickly respond to spills with remedial actions.

MAINTENANCE:

- ▶ Observe daily for any non-storm water discharge.
- ▶ Look for runoff bypassing ends of berms or undercutting berms.
- ▶ Repair or replace damaged areas of the berm and remove accumulated sediment.
- ▶ Recompect soil around berm as necessary to prevent piping.

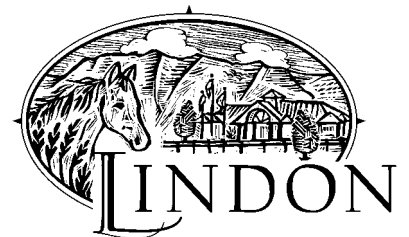

Adapted from Salt Lake County BMP Fact Sheet

TARGETED POLLUTANTS

- Sediment
- Nutrients
- Toxic Materials
- Oil & Grease
- Floatable Materials
- Other Construction Waste

- High Impact
- Medium Impact
- Low or Unknown Impact

IMPLEMENTATION REQUIREMENTS

- Capital Costs
- O&M Costs
- Maintenance
- Training

- High
- Medium
- Low

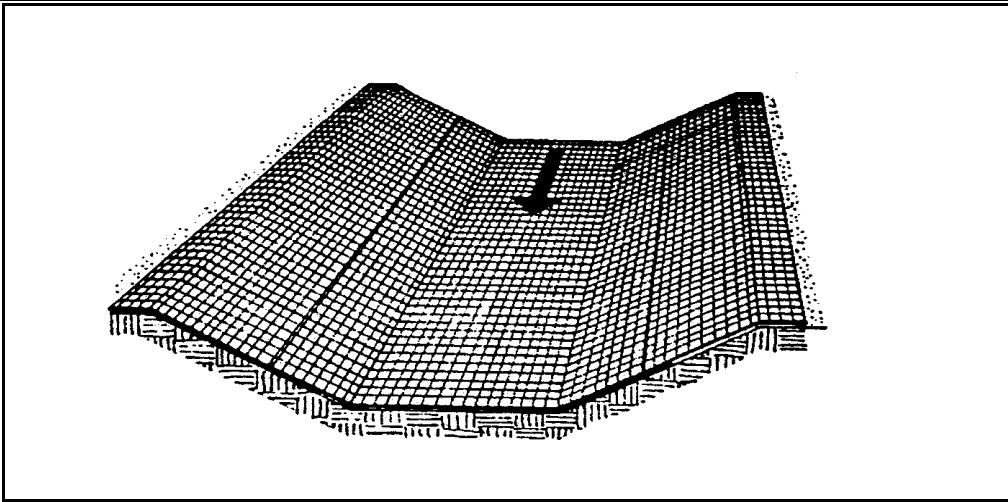

DESCRIPTION:

Erosion control blankets are used in place of mulch on areas of high velocity runoff and/or steep grade, to aid in controlling erosion on critical areas by protecting young vegetation. See related Geotextiles and Mats BMP Fact Sheet (GM).

APPLICATIONS:

- ▶ Where vegetation is likely to grow too slowly to provide adequate cover.
- ▶ In areas subject to high winds where mulch would not be effective.
- ▶ On steep slopes in which planting and mulching alone may not be as effective.

INSTALLATION/APPLICATION CRITERIA:

- ▶ Install erosion control blankets parallel to the direction of the slope.
- ▶ In ditches, apply in direction of the flow.
- ▶ Place erosion control blankets loosely on soil - do not stretch.
- ▶ Ends of blankets should be buried no less than six inches deep.
- ▶ Staple the edges of the blanket at least every three feet.

LIMITATIONS:

- ▶ Not recommended in areas which are still under construction.

MAINTENANCE:

- ▶ Check for erosion and undermining periodically, particularly after rainstorms.
- ▶ Repair dislocations or failures immediately.
- ▶ If washouts occur, reinstall after repairing slope damage.
- ▶ Monitor until permanently stabilized.

OBJECTIVES

- Housekeeping Practices
- Contain Waste
- Minimize Disturbed Areas
- Stabilize Disturbed Areas
- Protect Slopes/Channels
- Control Site Perimeter
- Control Internal Erosion

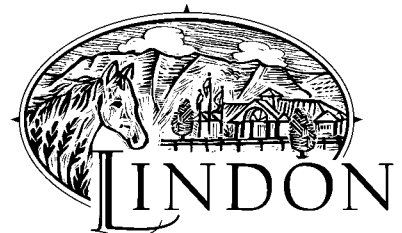

Adapted from Salt Lake County BMP Fact Sheet

TARGETED POLLUTANTS

- Sediment
- Nutrients
- Toxic Materials
- Oil & Grease
- Floatable Materials
- Other Waste

- High Impact
- Medium Impact
- Low or Unknown Impact

IMPLEMENTATION REQUIREMENTS

- Capital Costs
- O&M Costs
- Maintenance
- Training

- High Medium Low

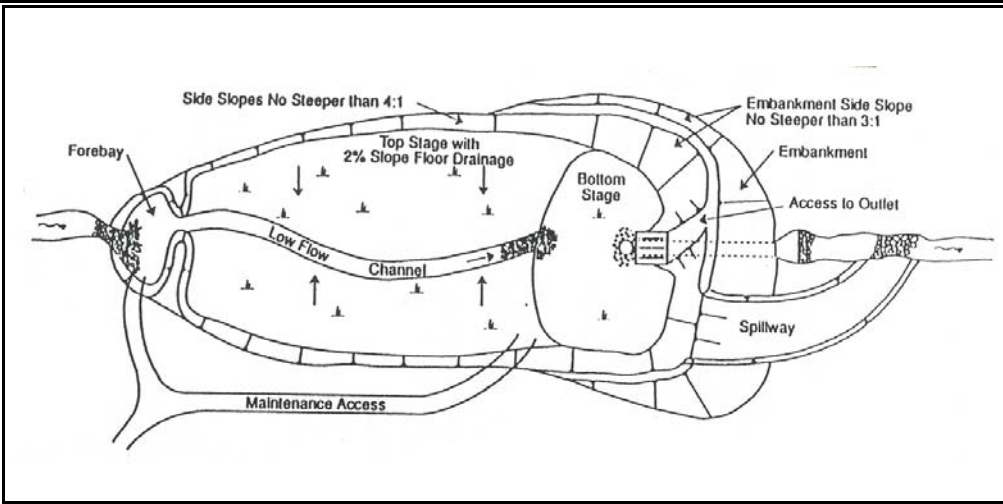

CONSIDERATIONS

- Soils
- Area Required
- Slope
- Water Availability
- Aesthetics
- Hydraulic Head
- Environmental Side Effects

DESCRIPTIONS:

Extended detention basins are dry between storms. During a storm the basin fills. A bottom outlet releases the storm water slowly to provide time for sediments to settle.

APPLICATION:

- ▶ Objective is to remove only particulate pollutants.
- ▶ Use where lack of water prevents the use of wet ponds, wetlands or biofilters.
- ▶ Use where wet ponds or wetlands would cause unacceptable mosquito conditions.

INSTALLATION/APPLICATION CRITERIA:

- ▶ Basin volume is sized to capture a particular fraction of the runoff.
- ▶ Drawdown time of 24 to 40 hours is required.
- ▶ A shallow basin with large surface area performs better than a deep basin with the same volume.
- ▶ Place energy dissipater at the entrance to minimize bottom erosion and resuspension.
- ▶ Vegetate side slopes and bottom to the maximum extent practical.
- ▶ If side erosion is particularly severe, consider paving or soil stabilization.
- ▶ If floatables are a problem, protect outlet with a trash rack or other device.
- ▶ Provide bypass or pass through capabilities for 100-year storm.

LIMITATIONS:

- ▶ May be less reliable than other treatment control BMPs. Inability to vegetate banks and bottom may result in erosion and resuspension.
- ▶ Limitation of the orifice diameter may preclude use in small watersheds.
- ▶ Requires differential elevation between inlet and outlet.

MAINTENANCE:

- ▶ Check outlet regularly for clogging.
- ▶ Check banks and bottom of basin for erosion and correct as necessary.
- ▶ Remove sediment when accumulation reaches 6-inches, or if resuspension is observed.

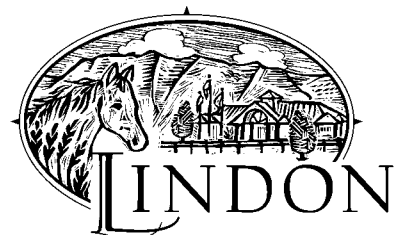

Adapted from Salt Lake County BMP Fact Sheet

TARGETED POLLUTANTS

- Sediment
- Nutrients
- Heavy Metals
- Toxic Materials
- Oxygen Demanding Substances
- Oil & Grease
- Floatable Materials
- Bacteria & Viruses

- High Impact
- Medium Impact
- Low or Unknown Impact

IMPLEMENTATION REQUIREMENTS

- Capital Costs
- O&M Costs
- Maintenance
- Training

- High
- Medium
- Low

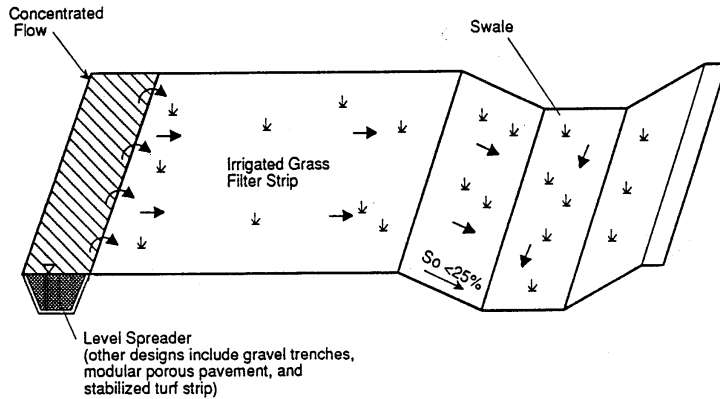

OBJECTIVES

- Housekeeping Practices
- Contain Waste
- Minimize Disturbed Areas
- Stabilize Disturbed Areas
- Protect Slopes/Channels
- Control Site Perimeter
- Control Internal Erosion

GENERAL DESCRIPTION:

Filter strips are 20-foot-wide strips of natural or planted vegetation around a construction site. They are designed to cause deposition of sediments within the vegetation layer.

APPLICATIONS:

- ▶ Suited for areas where the soils are well drained or moderately well drained.
- ▶ Areas where the bedrock and the water table are well below the surface.

INSTALLATION/APPLICATION CRITERIA:

- ▶ Make sure the vegetative cover is dense enough to protect underlying soil while causing sediment to settle.
- ▶ Filter strip must be approximately 20 feet wide to function well.
- ▶ The length should be approximately 50 to 75 feet. Where slopes become steeper the length of the strip must be increased.

LIMITATIONS:

- ▶ Only applicable in areas where vegetation is previously established or where sod is added.
- ▶ Vegetated filter strips will not function well on steep slopes, in hilly areas, or in highly paved areas.
- ▶ Sites with slopes of 15 percent or more may not be suitable for filtering storm water flows.

MAINTENANCE:

- ▶ Check for channels and repair.
- ▶ Provide rock aprons to aid in slowing flow if necessary.
- ▶ Maintain vegetation at optimal height and thickness.

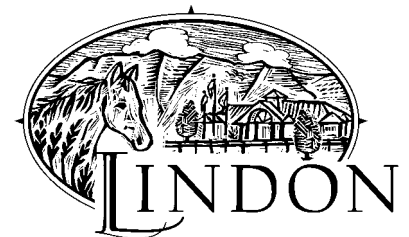

Adapted from Salt Lake County BMP Fact Sheet

TARGETED POLLUTANTS

- Sediment
- Nutrients
- Toxic Materials
- Oil & Grease
- Floatable Materials
- Other Waste

- High Impact
- Medium Impact
- Low or Unknown Impact

IMPLEMENTATION REQUIREMENTS

- Capital Costs
- O&M Costs
- Maintenance
- Training

- High
- Medium
- Low

FLOW RATES VARY ACCORDING TO MANUFACTURER

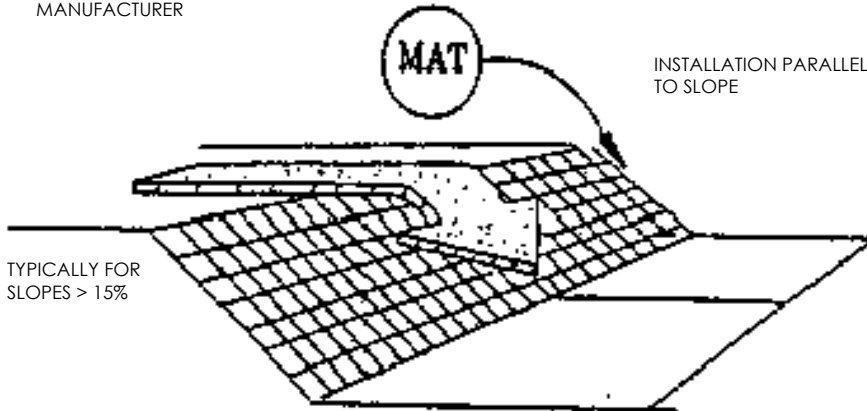

OBJECTIVES

- Housekeeping Practices
- Contain Waste
- Minimize Disturbed Areas
- Stabilize Disturbed Areas
- Protect Slopes/Channels
- Control Site Perimeter
- Control Internal Erosion

DESCRIPTION:

Mattings made of natural or synthetic material which are used to temporarily or permanently stabilize soil. See the related Erosion Control Blankets BMP Fact Sheet (ECB).

APPLICATION:

- ▶ Typically suited for post-construction site stabilization, but may be used for temporary stabilization of highly erosive soils.
- ▶ Channels and streams.
- ▶ Steep slopes.

INSTALLATION/APPLICATION CRITERIA:

- ▶ Mattings may be applied to disturbed soils and where existing vegetation has been removed.
- ▶ The following organic matting materials provide temporary protection until permanent vegetation is established, or when seasonal circumstances dictate the need for temporary stabilization until weather or construction delays are resolved: Jute mattings and straw mattings.
- ▶ The following synthetic mattings may be used for either temporary or post-construction stabilization, both with and without vegetation: excelsior matting, glass fiber matting, mulch matting.
- ▶ Staples are needed to anchor the matting.

LIMITATIONS:

- ▶ Mattings are more costly than other BMP practices, limiting their use to areas where other BMPs are ineffective (e.g., channels, steep slopes).
- ▶ May delay seed germination, due to reduction in soil temperature.
- ▶ Installation requires experienced contractor to ensure soil stabilization and erosion protection.

MAINTENANCE:

- ▶ Inspect monthly and after significant rainfall.
- ▶ Re-anchor loosened matting and replace missing matting and staples as required.



Adapted from Salt Lake County BMP Fact Sheet

TARGETED POLLUTANTS

- Sediment
- Nutrients
- Toxic Materials
- Oil & Grease
- Floatable Materials
- Other Waste

- High Impact
- Medium Impact
- Low or Unknown Impact

IMPLEMENTATION REQUIREMENTS

- Capital Costs
- O&M Costs
- Maintenance
- Training

- High Medium Low



Soils exposed from land grading activities are very vulnerable to erosion

OBJECTIVES

- Housekeeping Practices
- Contain Waste
- Minimize Disturbed Areas
- Stabilize Disturbed Areas
- Protect Slopes/Channels
- Control Site Perimeter
- Control Internal Erosion

DESCRIPTION:

Control soil erosion by minimizing the exposure of bare soil to erosive forces. This is done by

- 1) limiting the amount of land disturbed at one time in preparation for construction
- 2) limiting the amount of time between the disturbance of soil and protection or stabilization of disturbed soils, and
- 3) using grading practices to protect exposed soils susceptible to storm water runoff.

Related practices include construction sequencing, preservation of existing vegetation, erosion control practices and sediment control practices.

APPROACH:

- Limit the area of disturbance to those areas requiring grading. This preserves existing vegetation and reduces the vulnerability of soil to erosion.
- Based on erosion potential and sediment control measures on the site, establish what areas are to be graded at one time.
- An undisturbed buffer zone containing vegetation at the lowest elevation of a construction site can reduce the transport of sediment off site.
- Initiate soil protection measures during the course of work to minimize the length of time soil is exposed to erosive forces.
- Conduct work in stages so that construction or soil stabilization occurs promptly after disturbance of soil.
- Establish a schedule governing the stabilization of disturbed slopes, both in terms of passage of time since commencement and completion of disturbance and in terms of planting season.
- Leaving the surface of the disturbed soil graded in a roughened condition (not smooth) can reduce the quantity and velocity of storm water runoff.
- Prevent storm water runoff from running onto steep slopes from above.
- Avoid long, steep cut or fill slopes that allow runoff water of sufficient quantity or velocity to cut into and erode the slope.

LIMITATIONS:

- The specific approach to grading on a particular site depends on the conditions of the site and surrounding land; engineering judgment is required to design the approach best suited for each site.

MAINTENANCE:

- Practices may need to vary from the approved plan if erosion problems appear when storm water runoff occurs.

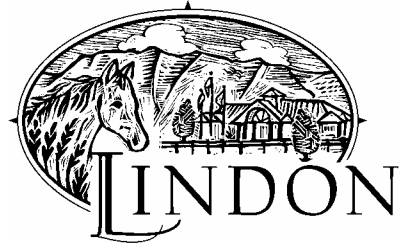

TARGETED POLLUTANTS

- Sediment
- Nutrients
- Heavy Metals
- Toxic Materials
- Oxygen Demanding Substances
- Oil & Grease
- Floatable Materials
- Bacteria & Viruses

- High Impact
- Medium Impact
- Low or Unknown Impact

IMPLEMENTATION REQUIREMENTS

- Capital Costs
- O&M Costs
- Maintenance
- Training

- High
- Medium
- Low

BMP: Grassed Swales

GS



Grassed swales can be used along roadsides and parking lots to collect and treat storm water runoff

APPLICATIONS

- Manufacturing
- Material Handling
- Vehicle Maintenance
- Construction
- Commercial Activities
- Roadways
- Waste Containment
- Housekeeping Practices

DESCRIPTION:

A series of vegetated, open channel management practices designed specifically to treat and attenuate storm water runoff. Storm water is treated through filtering by the vegetation in the channel, filtering through a subsoil matrix, and/or infiltration into the underlying soils.

APPROACH:

- Grassed swales can be applied in most situations with some restrictions. Swales are very well suited for treating highway or residential road runoff because they are linear practices.
- Grassed channels are a good treatment option within watersheds that drain to cold water streams. These practices do not pond water for a long period of time and often induce infiltration. As a result, standing water will not typically be subjected to warming by the sun in these practices.
- Grassed swales should be used on sites with relatively flat slopes of less than 4 percent slope; 1 to 2 percent slope is recommended.
- A small fore-bay should be used at the front of the swale to trap incoming sediments. A pea gravel diaphragm, a small trench filled with river run gravel, should be used as pretreatment for runoff entering the sides of the swale.
- Swales should also have the capacity to pass larger storms (typically a 10-year storm) safely.

LIMITATIONS:

- Grassed swales cannot treat a very large drainage area.
- Wet swales may become a nuisance due to mosquito breeding.

MAINTENANCE:

Maintenance of grassed swales mostly involves maintenance of the grass or wetland plant cover.



TARGETED POLLUTANTS

- Sediment
- Nutrients
- Heavy Metals
- Toxic Materials
- Oxygen Demanding Substances
- Oil & Grease
- Floatable Materials
- Bacteria & Viruses

- High Impact
- Medium Impact
- Low or Unknown Impact

IMPLEMENTATION REQUIREMENTS

- Capital Costs
- O&M Costs
- Maintenance
- Training

- High Medium Low



DESCRIPTION:

A combination of wood fiber mulch, processed grass, or hay or straw mulch and a tacking agent. It is made into a slurry, then applied to bare slopes or other bare areas to provide temporary stabilization.

APPLICATIONS:

- ▶ Small roadside slopes.
- ▶ Large, relatively flat areas.

INSTALLATION/APPLICATION CRITERIA:

- ▶ Legume seeds should be pellet inoculated with the appropriate bacteria.
- ▶ The seed should not remain in the hydromulcher tank for more than 30 minutes.
- ▶ Wood fiber may be dyed to aid in uniform application.
- ▶ Slurry should be uniformly applied until an adequate coverage is achieved.
- ▶ The applicator should not be directed at one location for a long period of time; erosion will occur.

LIMITATIONS:

- ▶ Will lose effectiveness after 1 year.
- ▶ Can use only on physically stable slopes (at natural angle of repose, or less).

MAINTENANCE:

- ▶ Periodically inspect for damage caused by wind, water, or human disturbance.
- ▶ Promptly repair damaged areas.

OBJECTIVES

- Housekeeping Practices
- Contain Waste
- Minimize Disturbed Areas
- Stabilize Disturbed Areas
- Protect Slopes/Channels
- Control Site Perimeter
- Control Internal Erosion

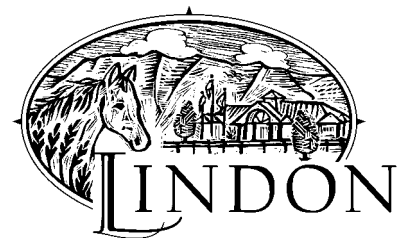

Adapted from Salt Lake County BMP Fact Sheet

TARGETED POLLUTANTS

- Sediment
- Nutrients
- Toxic Materials
- Oil & Grease
- Floatable Materials
- Other Waste

- High Impact
- Medium Impact
- Low or Unknown Impact

IMPLEMENTATION REQUIREMENTS

- Capital Costs
- O&M Costs
- Maintenance
- Training

- High Medium Low

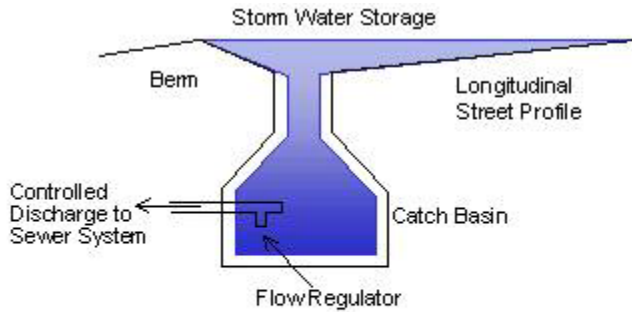

Note: Not to scale and great vertical exaggeration

Catch basins can be equipped with flow restrictors to temporarily detain storm water in the conveyance system

APPLICATIONS

- Manufacturing
- Material Handling
- Vehicle Maintenance
- Construction
- Commercial Activities
- Roadways
- Waste Containment
- Housekeeping Practices

DESCRIPTION:

In-line storage refers to a number of practices designed to use the storage within the storm drain system to detain flows. While these practices can reduce storm peak flows, they are unable to improve water quality or protect downstream channels. Devices can slow the rate of flow by backing up flow, as in the case of a dam or weir, or through the use of vortex valves, devices that reduce flow rates by creating a helical flow path in the structure.

APPROACH:

- In-line storage practices serve the same purpose as traditional detention basins
- These practices can act as a surrogate for aboveground storage when little space is available for aboveground storage facilities.

LIMITATIONS:

- In-line storage practices only control flow, and thus are not able to improve the water quality of storm water runoff.
- If improperly designed, these practices may cause upstream flooding.
- Flow regulators cannot be applied to all storm drain systems. In older cities, the storm drainpipes may not be oversized, and detaining storm water within them would cause upstream flooding.

MAINTENANCE:

- Flow regulators require very little maintenance, because they are designed to be "self-cleaning," much like the storm drain system.
- For some designs, such as check dams, regulations will require only moderate construction in order to modify the structure's design.

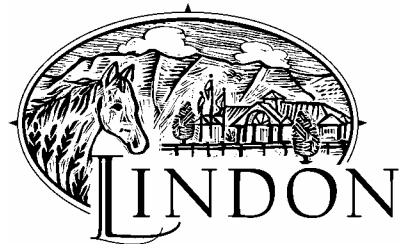

TARGETED POLLUTANTS

- Sediment
- Nutrients
- Heavy Metals
- Toxic Materials
- Oxygen Demanding Substances
- Oil & Grease
- Floatable Materials
- Bacteria & Viruses

- High Impact
- Medium Impact
- Low or Unknown Impact

IMPLEMENTATION REQUIREMENTS

- Capital Costs
- O&M Costs
- Maintenance
- Training

- High
- Medium
- Low

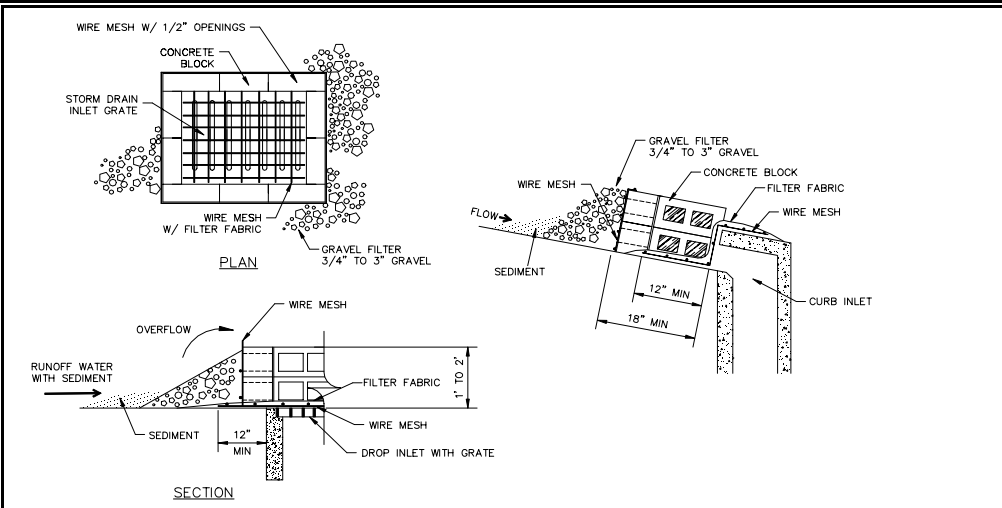

OBJECTIVES

- Housekeeping Practices
- Contain Waste
- Minimize Disturbed Areas
- Stabilize Disturbed Areas
- Protect Slopes/Channels
- Control Site Perimeter
- Control Internal Erosion

DESCRIPTION:

Concrete block and gravel filter placed over inlet to storm drain system.

APPLICATION:

Construct at inlets in paved or unpaved areas where upgradient area is to be disturbed by construction activities.

INSTALLATION/APPLICATION CRITERIA:

- ▶ Place wire mesh (with 1/2 inch openings) over the inlet grate extending one foot past the grate in all directions.
- ▶ Place concrete blocks around the inlet with openings facing outward. Stack blocks to minimum height of 12-inches and maximum height of 24-inches.
- ▶ Place wire mesh around outside of blocks.
- ▶ Place gravel (3/4" to 3") around blocks.

LIMITATIONS:

- ▶ Recommended for maximum drainage area of one acre.
- ▶ Excess flows may bypass the inlet requiring down gradient controls.
- ▶ Ponding will occur at inlet.

MAINTENANCE:

- ▶ Inspect inlet protection after every large storm event and at a minimum of once monthly.
- ▶ Remove sediment accumulated when it reaches 4-inches in depth.
- ▶ Replace filter fabric and clean or replace gravel if clogging is apparent.



Adapted from Salt Lake County BMP Fact Sheet

TARGETED POLLUTANTS

- Sediment
- Nutrients
- Toxic Materials
- Oil & Grease
- Floatable Materials
- Other Waste

- High Impact
- Medium Impact
- Low or Unknown Impact

IMPLEMENTATION REQUIREMENTS

- Capital Costs
- O&M Costs
- Maintenance
- Training

- High
- Medium
- Low

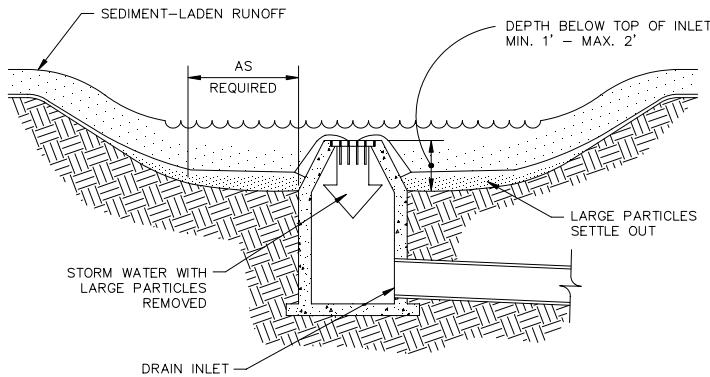

OBJECTIVES

- Housekeeping Practices
- Contain Waste
- Minimize Disturbed Areas
- Stabilize Disturbed Areas
- Protect Slopes/Channels
- Control Site Perimeter
- Control Internal Erosion



Adapted from Salt Lake County BMP Fact Sheet

DESCRIPTION:

An area excavated around a storm drain inlet to impound water below the inlet.

APPLICATION:

Construct at storm drainage inlets located downgradient of areas to be disturbed by construction (for inlets in paved areas see other information sheets for inlet protection).

INSTALLATION/APPLICATION CRITERIA:

- ▶ Provide upgradient sediment controls, such as silt fence during construction of inlet.
- ▶ When construction of inlet is complete, excavate adjacent area 1 to 2 feet lower than the grate elevation. Size of excavated area should be based on soil type and contributing acreage.

LIMITATIONS:

- ▶ Recommended maximum contributing drainage area of one acre.
- ▶ Limited to inlets located in open unpaved areas.
- ▶ Requires flat area adjacent to inlet.

MAINTENANCE:

- ▶ Inspect inlet protection following storm event and at a minimum of once monthly.
- ▶ Remove accumulated sediment when it reaches one half of the excavated sump below the grate.
- ▶ Repair side slopes as required.

TARGETED POLLUTANTS

- Sediment
- Nutrients
- Toxic Materials
- Oil & Grease
- Floatable Materials
- Other Waste

- High Impact
- Medium Impact
- Low or Unknown Impact

IMPLEMENTATION REQUIREMENTS

- Capital Costs
- O&M Costs
- Maintenance
- Training

- High Medium Low

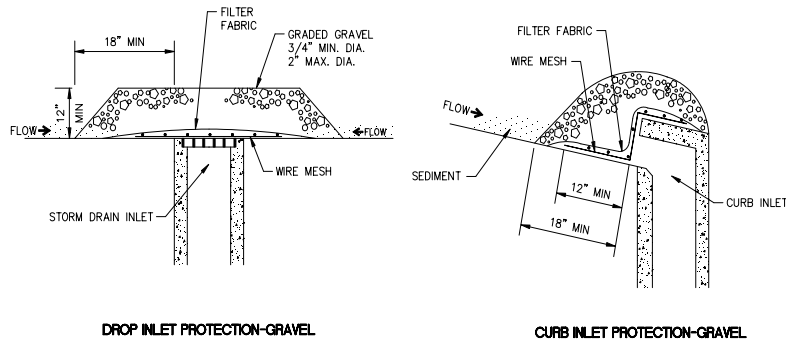

OBJECTIVES

- Housekeeping Practices
- Contain Waste
- Minimize Disturbed Areas
- Stabilize Disturbed Areas
- Protect Slopes/Channels
- Control Site Perimeter
- Control Internal Erosion

DESCRIPTION:

Placement of gravel filter over inlet to storm drain to filter storm water runoff.

APPLICATION:

Construct at inlets in paved or unpaved areas where upgradient area is to be disturbed by construction activities.

INSTALLATION/APPLICATION CRITERIA:

- ▶ Place wire mesh (with 1/2 inch openings) over the inlet grate extending one foot past the grate in all directions.
- ▶ Place filter fabric over the mesh. Filter fabric should be selected based on soil type.
- ▶ Place graded gravel, to a minimum depth of 12-inches, over the filter fabric and extending 18-inches past the grate in all directions.

LIMITATIONS:

- ▶ Recommended for maximum drainage area of one acre.
- ▶ Excess flows may bypass the inlet requiring down gradient controls.
- ▶ Ponding will occur at inlet.

MAINTENANCE:

- ▶ Inspect inlet protection after every large storm event and at a minimum of once monthly.
- ▶ Remove sediment accumulated when it reaches 4-inches in depth.
- ▶ Replace filter fabric and clean or replace gravel if clogging is apparent.



Adapted from Salt Lake County BMP Fact Sheet

TARGETED POLLUTANTS

- Sediment
- Nutrients
- Toxic Materials
- Oil & Grease
- Floatable Materials
- Other Waste

- High Impact
- Medium Impact
- Low or Unknown Impact

IMPLEMENTATION REQUIREMENTS

- Capital Costs
- O&M Costs
- Maintenance
- Training

- High
- Medium
- Low

INLET PROTECTION

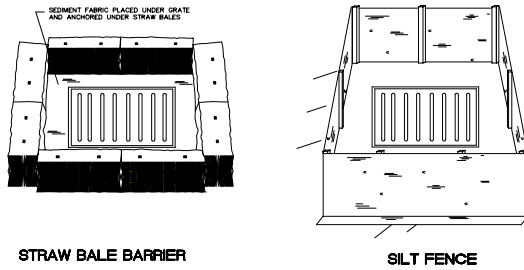

SEE INDIVIDUAL BMP INFORMATION SHEETS FOR INSTRUCTIONS FOR CONSTRUCTION OF STRAW BALE BARRIER AND SILT FENCE..

OBJECTIVES

- Housekeeping Practices
- Contain Waste
- Minimize Disturbed Areas
- Stabilize Disturbed Areas
- Protect Slopes/Channels
- Control Site Perimeter
- Control Internal Erosion

DESCRIPTION:

Sediment barrier erected around storm drain inlet.

APPLICATION:

Construct at storm drainage inlets located downgradient of areas to be disturbed by construction (for inlets in paved areas see other information sheets for inlet protection).

INSTALLATION/APPLICATION CRITERIA:

- ▶ Provide upgradient sediment controls, such as silt fence during construction of inlet.
- ▶ When construction of inlet is complete, erect straw bale barrier or silt fence surrounding perimeter of inlet. Follow instructions and guidelines on individual BMP information sheets for straw bale barrier and silt fence construction.

LIMITATIONS:

- ▶ Recommended maximum contributing drainage area of one acre.
- ▶ Limited to inlets located in open unpaved areas.
- ▶ Requires shallow slopes adjacent to inlet.

MAINTENANCE:

- ▶ Inspect inlet protection following storm event and at a minimum of once monthly.
- ▶ Remove accumulated sediment when it reaches 4-inches in depth.
- ▶ Repair or realign barrier/fence as needed.
- ▶ Look for bypassing or undercutting and recompact soil around barrier/fence as required.

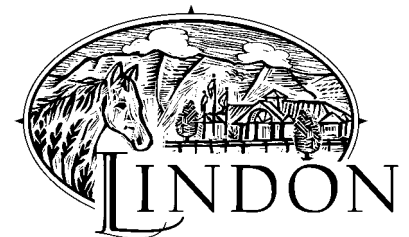

Adapted from Salt Lake County BMP Fact Sheet

TARGETED POLLUTANTS

- Sediment
- Nutrients
- Toxic Materials
- Oil & Grease
- Floatable Materials
- Other Waste

- High Impact
- Medium Impact
- Low or Unknown Impact

IMPLEMENTATION REQUIREMENTS

- Capital Costs
- O&M Costs
- Maintenance
- Training

- High
- Medium
- Low

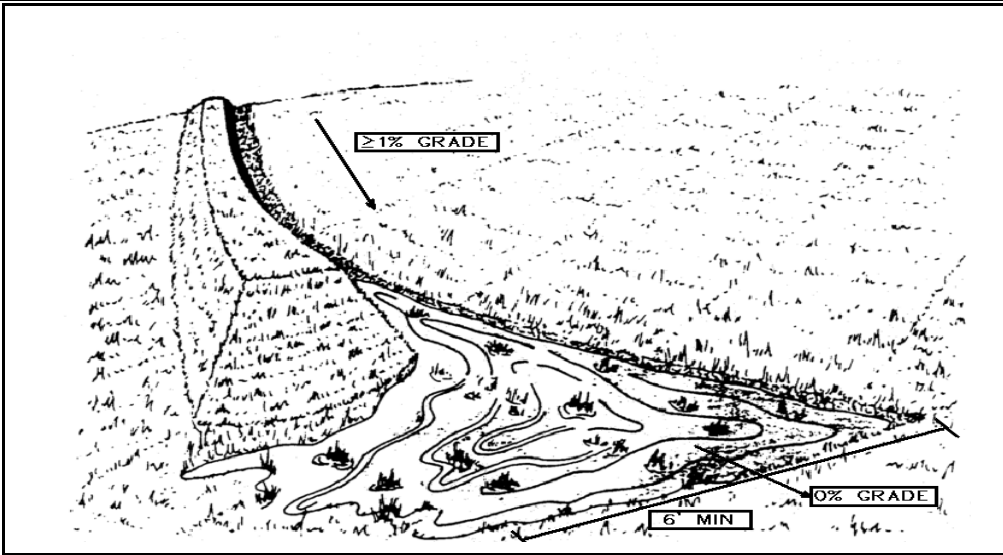

DESCRIPTION:

Level spreaders are devices used at storm water outlets to spread out collected storm water flows into sheet flow (runoff that flows over ground surface in a thin, even layer). Typically, a level spreader consists of a depression in the soil surface that spreads the flow onto a flat area across a gentle slope. Level spreaders then release the storm water flow onto level areas stabilized by vegetation to reduce speed and increase infiltration.

APPLICATION:

Level spreaders are most often used as an outlet for temporary or permanent storm water conveyances or dikes. Runoff that contains high sediment loads should be treated in a sediment trapping device prior to release into a level spreader.

INSTALLATION/APPLICATION CRITERIA:

- ▶ The length of the spreader depends upon the amount of water that flows through the conveyance.
- ▶ Larger volumes of water need more space to even out.
- ▶ Level spreaders are generally used with filter strips (see Filter Strips BMP).
- ▶ The depressions are seeded with vegetation (see Permanent & Temporary Seeding BMP).
- ▶ Level spreaders should be constructed on natural soils and not on fill material.
- ▶ The entrance to the spreader should be level so that the flow can spread out evenly.
- ▶ Level Spreader should have a grade of 0%; minimum width should be 6'.

LIMITATIONS:

- ▶ Can easily develop "short circuiting" (concentration of flows into small streams instead of sheet flow over the spreader) because of erosion or other disturbance.
- ▶ Cannot handle large quantities of sediment-laden storm water.

MAINTENANCE:

- ▶ The spreader should be inspected after every storm event to check for damage.
- ▶ If ponding or erosion channels develop, the spreader should be regraded.
- ▶ Dense vegetation should be maintained and damaged areas reseeded as needed.

CONSIDERATIONS

- Soils
- Area Required
- Slope
- Water Availability
- Aesthetics
- Hydraulic Head
- Environmental Side Effects

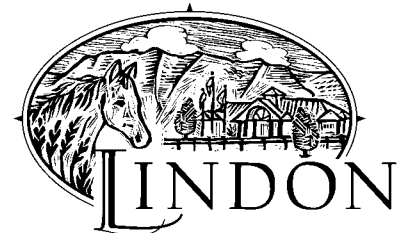

Adapted from Salt Lake County BMP Fact Sheet

TARGETED POLLUTANTS

- Sediment
- Nutrients
- Heavy Metals
- Toxic Materials
- Oxygen Demanding Substances
- Oil & Grease
- Floatable Materials
- Bacteria & Viruses

- High Impact
- Medium Impact
- Low or Unknown Impact

IMPLEMENTATION REQUIREMENTS

- Capital Costs
- O&M Costs
- Maintenance
- Training

- High
- Medium
- Low

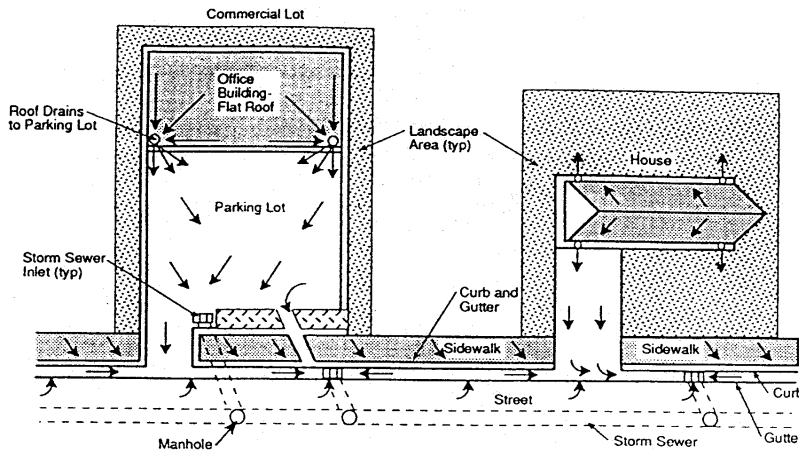

CONSIDERATIONS

- Soils
- Area Required
- Slope
- Water Availability
- Aesthetics
- Hydraulic Head
- Environmental Side Effects

DESCRIPTION:

Minimizing directly connected impervious areas (DCIAs) is a structural BMP strategy that requires a basic change in drainage design philosophy. The basic principle is to direct storm water runoff to landscaped areas, grass buffer strips, and vegetated swales to slow down the rate of runoff, reduce runoff volumes, attenuate peak flows, and encourage filtering and infiltration of storm water.

APPLICATIONS:

It can be made an integral part of drainage planning for any development.

INSTALLATION/APPLICATION CRITERIA:

- ▶ Use on sites with general terrain slopes flatter than 3-4%.
- ▶ Design the site drainage flowpath to maximize flow over vegetated areas before leaving a site.
- ▶ Minimize ground slopes to limit erosion and slow down water flow.
- ▶ Select vegetation that will not only survive, but also enhance water quality.

LIMITATIONS:

- ▶ Potential increase in site open space requirements over the traditional development systems.
- ▶ Introduction of a non-conventional development design strategy.
- ▶ Infiltration of water near building foundations and parking lots is a concern.
- ▶ Will likely result in increased maintenance along the swales.

MAINTENANCE:

- ▶ Maintain grass and other vegetation.
- ▶ Pick up debris.
- ▶ Conduct ongoing inspections for potential erosion problems and changes in drainage patterns.
- ▶ Remove sediment buildup and replace damaged grass cover.

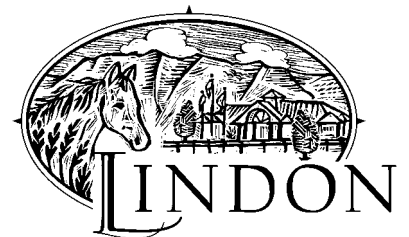

Adapted from Salt Lake County BMP Fact Sheet

TARGETED POLLUTANTS

- Sediment
- Nutrients
- Heavy Metals
- Toxic Materials
- Oxygen Demanding Substances
- Oil & Grease
- Floatable Materials
- Bacteria & Viruses

- High Impact
- Medium Impact
- Low or Unknown Impact

IMPLEMENTATION REQUIREMENTS

- Capital Costs
- O&M Costs
- Maintenance
- Training

- High Medium Low

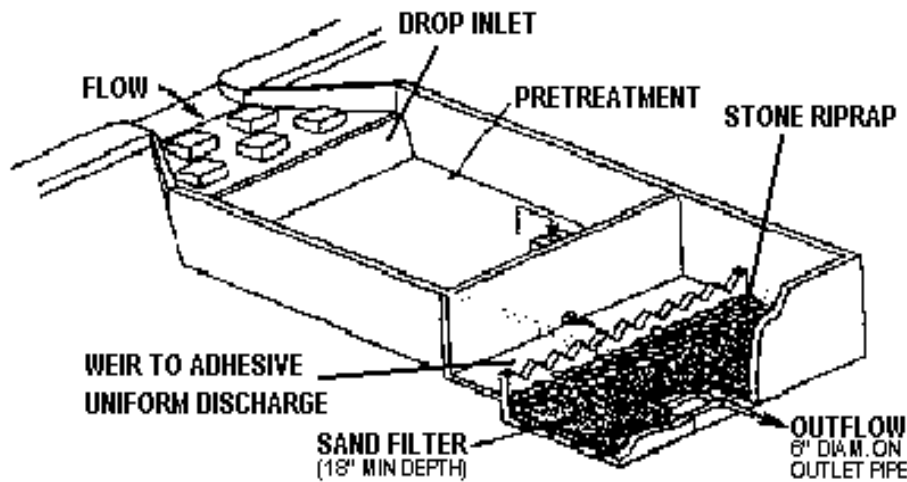

CONSIDERATIONS

- Soils
- Area Required
- Slope
- Water Availability
- Aesthetics
- Hydraulic Head
- Environmental Side Effects

DESCRIPTION:

Consists of a settling basin followed by a filter. The most common filter media is sand; some use peat/sand mixture.

APPLICATION:

- ▶ Objective is to remove only sediment (particulate pollutants).
- ▶ Use where unavailability of water prevents the use of wet ponds, wetlands, or biofilters.
- ▶ Can be placed underground.
- ▶ Suitable for individual developments and small tributary areas up to about 100 acres.
- ▶ May require less space than other treatment control BMPs.

INSTALLATION/APPLICATION CRITERIA:

- ▶ Settling basin smaller than wet or extended detention basin.
- ▶ Spread flow across filter.
- ▶ Place filter offline to protect from extreme events.
- ▶ Minimize erosion in settling basin.

LIMITATIONS:

- ▶ Filter may require more frequent maintenance than most of the other BMPs.
- ▶ Head loss.
- ▶ Dissolved pollutants are not captured by sand.
- ▶ Severe clogging potential if exposed soil surfaces exist upstream.

MAINTENANCE:

Clean filter surface about twice annually; or more often if watershed is excessively erosive.



Adapted from Salt Lake County BMP Fact Sheet

TARGETED POLLUTANTS

- Sediment
- Nutrients
- Heavy Metals
- Toxic Materials
- Oxygen Demanding Substances
- Oil & Grease
- Floatable Materials
- Bacteria & Viruses

- High Impact
- Medium Impact
- Low or Unknown Impact

IMPLEMENTATION REQUIREMENTS

- Capital Costs
- O&M Costs
- Maintenance
- Training

- High Medium Low

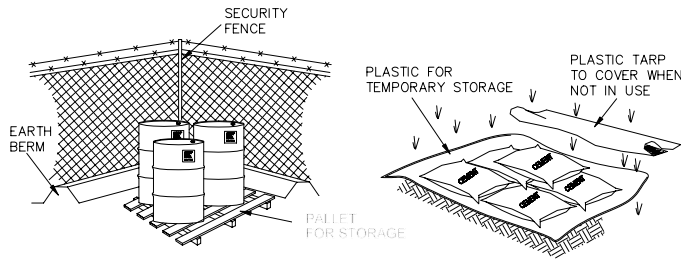

- ▶ CONTROLLED STORAGE LOCATION
- ▶ BERMED PERIMETER IMPOUNDMENT
- ▶ STORAGE OFF GROUND
- ▶ COVER WHEN NOT IN USE

OBJECTIVES

- Housekeeping Practices
- Contain Waste
- Minimize Disturbed Areas
- Stabilize Disturbed Areas
- Protect Slopes/Channels
- Control Site Perimeter
- Control Internal Erosion

DESCRIPTION:

Controlled storage of on-site materials.

APPLICATION:

- ▶ Storage of hazardous, toxic, and all chemical substances.
- ▶ Any construction site with outside storage of materials.

INSTALLATION/APPLICATION CRITERIA:

- ▶ Designate a secured area with limited access as the storage location. Ensure no waterways or drainage paths are nearby.
- ▶ Construct compacted earthen berm (See Earth Berm Barrier Information Sheet), or similar perimeter containment around storage location for impoundment in the case of spills.
- ▶ Ensure all on-site personnel utilize designated storage area. Do not store excessive amounts of material that will not be utilized on site.
- ▶ For active use of materials away from the storage area ensure materials are not set directly on the ground and are covered when not in use. Protect storm drainage during use.

LIMITATIONS:

- ▶ Does not prevent contamination due to mishandling of products.
- ▶ Spill Prevention and Response Plan still required.
- ▶ Only effective if materials are actively stored in controlled location.

MAINTENANCE:

- ▶ Inspect daily and repair any damage to perimeter impoundment or security fencing.
- ▶ Verify that materials are being correctly stored (i.e. standing upright, in labeled containers, tightly capped) and that no materials are being stored away from the designated location.

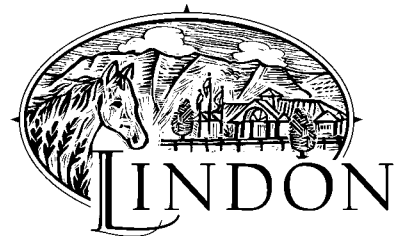

Adapted from Salt Lake County BMP Fact Sheet

TARGETED POLLUTANTS

- Sediment
- Nutrients
- Toxic Materials
- Oil & Grease
- Floatable Materials
- Other Waste

- High Impact
- Medium Impact
- Low or Unknown Impact

IMPLEMENTATION REQUIREMENTS

- Capital Costs
- O&M Costs
- Maintenance
- Training

- High Medium Low

DESCRIPTION:

Placement of material such as straw, grass, woodchips, woodfibers or fabricated matting over open area.

APPLICATION:

- ▶ Any exposed area to remain untouched longer than 14 days and that will be exposed less than 60 days (seed areas to be exposed in excess of 60 days).
- ▶ Areas that have been seeded.
- ▶ Stockpiled soil material.

Material	Application	Depth	Comments
<u>Gravel:</u> Washed 1/4" to 1-1/2"	9 cy/1000 sf	3 inches	Good for traffic areas Good for short slopes
<u>Straw:</u> Air-dried, free of seeds and coarse material	2-3 bales/1000 sf	2 inches min.	Subject to wind blowing Tack down or keep moist
<u>Wood Fiber Cellulose:</u> Free from growth inhibitors; dyed green	35 lb/1000 sf	1 inch	For critical areas, double application rate; Limit to slopes < 3% and < 150 feet

INSTALLATION/APPLICATION CRITERIA:

- ▶ Roughen area to receive mulch to create depressions that mulch material can settle into.
- ▶ Apply mulch to required thickness and anchor as necessary.
- ▶ Ensure material used is weed free and does not contain any constituents that will inhibit plant growth.

LIMITATIONS:

- ▶ Anchoring may be required to prevent migration of mulch material.
- ▶ Downgradient control may be required to prevent mulch material being transported to storm water system.

MAINTENANCE:

- ▶ Inspect mulched areas after every rainfall event and at a minimum of monthly.
- ▶ Replace mulch on any bare areas and reanchor as necessary.
- ▶ Clean and replace downgradient controls as necessary.

OBJECTIVES

- Housekeeping Practices
- Contain Waste
- Minimize Disturbed Areas
- Stabilize Disturbed Areas
- Protect Slopes/Channels
- Control Site Perimeter
- Control Internal Erosion



Adapted from Salt Lake County BMP Fact Sheet

TARGETED POLLUTANTS

- Sediment
- Nutrients
- Toxic Materials
- Oil & Grease
- Floatable Materials
- Other Waste

- High Impact
- Medium Impact
- Low or Unknown Impact

IMPLEMENTATION REQUIREMENTS

- Capital Costs
- O&M Costs
- Maintenance
- Training

- High
- Medium
- Low

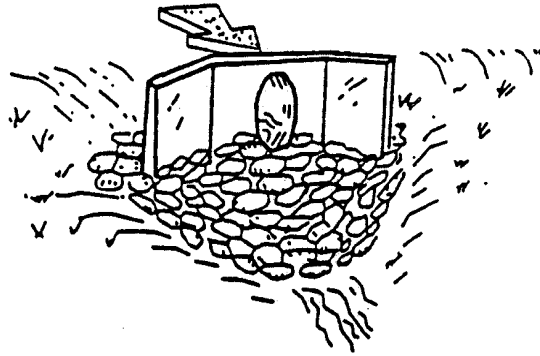

DESCRIPTION:

A rock outlet protection is a physical device composed of rock, grouted riprap, or concrete rubble which is placed at the outlet of a pipe to prevent scour of the soil caused by high pipe flow velocities, and to absorb flow energy to produce non-erosive velocities.

APPLICATIONS:

- ▶ Wherever discharge velocities and energies at the outlets of culverts, conduits, or channels are sufficient to erode the next downstream reach.
- ▶ Rock outlet protection is best suited for temporary use during construction because it is usually less expensive and easier to install than concrete aprons or energy dissipators.
- ▶ A sediment trap below the pipe outlet is recommended if runoff is sediment laden.
- ▶ Permanent rock riprap protection should be designed and sized by the engineer as part of the culvert, conduit or channel design.
- ▶ Grouted riprap should be avoided in areas of freeze and thaw because the grout will break up.

INSTALLATION/APPLICATION CRITERIA:

Rock outlet protection is effective when the rock is sized and placed properly. When this is accomplished, rock outlets do much to limit erosion at pipe outlets. Rock size should be increased for high velocity flows. Best results are obtained when sound, durable, angular rock is used.

LIMITATIONS:

- ▶ Large storms often wash away the rock outlet protection and leave the area susceptible to erosion.
- ▶ Sediment captured by the rock outlet protection may be difficult to remove without removing the rock.
- ▶ Outlet protection may negatively impact the channel habitat.

MAINTENANCE:

- ▶ Inspect after each significant rain for erosion and/or disruption of the rock, and repair immediately.
- ▶ Grouted or wire-tied rock riprap can minimize maintenance requirements.

OBJECTIVES

- Housekeeping Practices
- Contain Waste
- Minimize Disturbed Areas
- Stabilize Disturbed Areas
- Protect Slopes/Channels
- Control Site Perimeter
- Control Internal Erosion

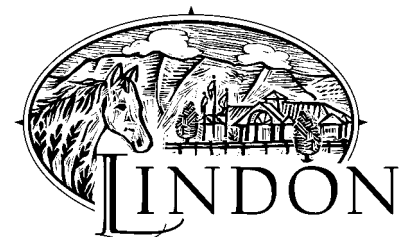

Adapted from Salt Lake County BMP Fact Sheet

TARGETED POLLUTANTS

- Sediment
- Nutrients
- Toxic Materials
- Oil & Grease
- Floatable Materials
- Other Waste

- High Impact
- Medium Impact
- Low or Unknown Impact

IMPLEMENTATION REQUIREMENTS

- Capital Costs
- O&M Costs
- Maintenance
- Training

- High
- Medium
- Low

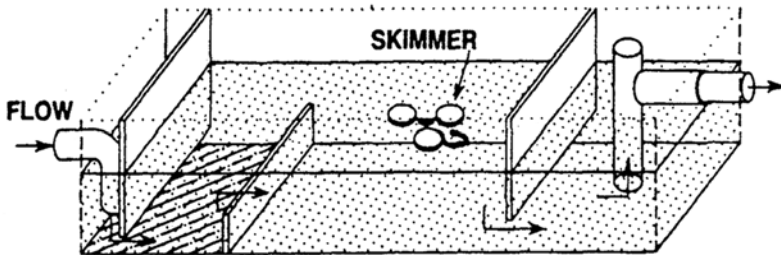

CONSIDERATIONS

- Soils
- Area Required
- Slope
- Water Availability
- Aesthetics
- Hydraulic Head
- Environmental Side Effects

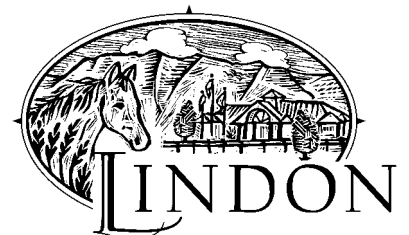

Adapted from Salt Lake County BMP Fact Sheet

DESCRIPTION:

Oil/Water separators are designed to remove a specific group of contaminants: petroleum compounds and grease. However, separators will also remove floatable debris and settleable solids. Two general types of oil/water separators are used: conventional gravity separator and the coalescing plate interceptor (CPI).

APPLICATION:

- ▶ Applicable to situations where the concentration of oil and grease related compounds is abnormally high and source control cannot provide effective control. The general types of businesses where this situation is likely are truck, car, and equipment maintenance and washing businesses, as well as businesses that perform maintenance on their own equipment and vehicles.
- ▶ Public facilities where separators may be required include marine ports, airfields, fleet vehicle maintenance and washing, facilities, and mass transit park-and-ride lots.
- ▶ Conventional separators are capable of removing oil droplets with diameters equal to or greater than 150 microns.
- ▶ A CPI separator should be used if smaller droplets must be removed.

INSTALLATION/APPLICATION CRITERIA:

- ▶ Sizing relates to anticipated influent oil concentration, water temperature and velocity, and the effluent goal.
- ▶ To maintain a reasonable separator size, it should be designed to bypass flows in excess of first flush.

LIMITATIONS:

- ▶ The lack of data on oil characteristics in stormwater leads to considerable uncertainty about performance.
- ▶ An air quality permit may be required.

MAINTENANCE:

Clean frequently of accumulated oil, grease, and floating debris.

TARGETED POLLUTANTS

- Sediment
- Nutrients
- Heavy Metals
- Toxic Materials
- Oxygen Demanding Substances
- Oil & Grease
- Floatable Materials
- Bacteria & Viruses

- High Impact
- Medium Impact
- Low or Unknown Impact

IMPLEMENTATION REQUIREMENTS

- Capital Costs
- O&M Costs
- Maintenance
- Training

- High Medium Low

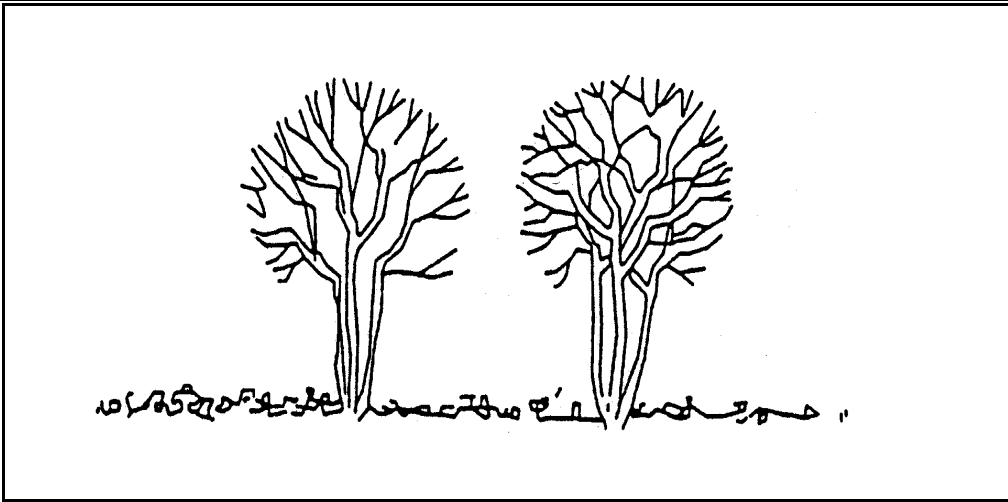

OBJECTIVES

- Housekeeping Practices
- Contain Waste
- Minimize Disturbed Areas
- Stabilize Disturbed Areas
- Protect Slopes/Channels
- Control Site Perimeter
- Control Internal Erosion

GENERAL DESCRIPTION:

Carefully planned preservation of existing vegetation minimizes the potential of removing or injuring existing trees, vines, shrubs and/or grasses that serve as erosion controls.

APPLICATIONS:

This technique is applicable to all types of sites. Areas where preserving vegetation can be particularly beneficial are floodplains, wetlands, stream banks, steep slopes, and other areas where erosion controls would be difficult to establish, install, or maintain.

INSTALLATION/APPLICATION CRITERIA:

- ▶ Clearly mark, flag or fence vegetation or areas where vegetation should be preserved.
- ▶ Prepare landscaping plans which include as much existing vegetation as possible and state proper care during and after construction.
- ▶ Define and protect with berms, fencing, signs, etc. a setback area from vegetation to be preserved.
- ▶ Propose landscaping plans which do not include plant species that compete with the existing vegetation.
- ▶ Do not locate construction traffic routes, spoil piles, etc. where significant adverse impact on existing vegetation may occur.

LIMITATIONS:

- ▶ Requires forward planning by the owner/developer, contractor and design staff.
- ▶ For sites with diverse topography, it is often difficult and expensive to save existing trees while grading the site satisfactorily for the planned development.
- ▶ May not be cost effective with high land costs.

MAINTENANCE:

- ▶ Inspection and maintenance requirements for protection of vegetation are low.
- ▶ Maintenance of native trees or vegetation should conform to landscape plan specifications.

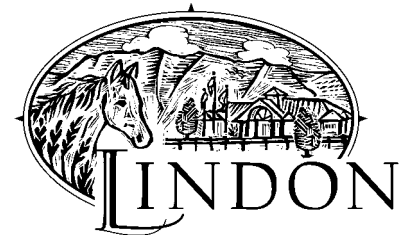

Adapted from Salt Lake County BMP Fact Sheet

TARGETED POLLUTANTS

- Sediment
- Nutrients
- Toxic Materials
- Oil & Grease
- Floatable Materials
- Other Waste

- High Impact
- Medium Impact
- Low or Unknown Impact

IMPLEMENTATION REQUIREMENTS

- Capital Costs
- O&M Costs
- Maintenance
- Training

- High
- Medium
- Low

BMP: Parking Lot Design

PLD



APPLICATIONS

- Manufacturing
- Material Handling
- Vehicle Maintenance
- Construction
- Commercial Activities
- Roadways
- Waste Containment
- Housekeeping Practices

DESCRIPTION:

Consider available design options to reduce the quantity and improve the quality of storm water runoff from parking lots. Related practices include filter strips, biofilters, grassed swales, and sediment traps.

CONSIDERATIONS:

- Shared parking reduces the total number of parking spaces needed for businesses adjacent to each other. Businesses having parking demand during the day on weekdays (such as office buildings) can often share parking spaces with businesses having weekend or evening parking demand (such as restaurants or movie theaters).
- The use of landscaped islands in parking lots reduces to the total impervious area of the parking lot, reducing the quantity of storm water runoff.
- Some parking lots can be designed such that storm water runoff flows across a landscaped area prior to being collected. This can both reduce the quantity of runoff and improve the quality of runoff.
- Include structural practices in parking lot design to reduce storm water runoff contamination. Examples include sediment traps in inlet boxes, oil/water separators, water quality inlets, and passing storm water over vegetation.
- Parking lots should not be larger than is necessary—they should provide adequate, but not excessive, parking.
- Technologies are available that allow for a natural turf surface on parking lots. Such surfaces support traffic loads and can be plowed of snow in the winter. They are generally used for overflow parking but can be used for primary parking as well. Grass pavement can both reduce storm water runoff and improve storm water runoff quality.

LIMITATIONS:

- Parking lot design is specific to each development site; some considerations may not apply on some sites.
- Shared parking is only viable where complimentary businesses are located adjacent to one another.

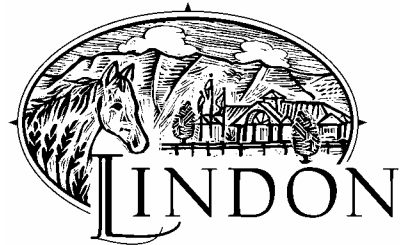

TARGETED POLLUTANTS

- Sediment
- Nutrients
- Heavy Metals
- Toxic Materials
- Oxygen Demanding Substances
- Oil & Grease
- Floatable Materials
- Bacteria & Viruses

- High Impact
- Medium Impact
- Low or Unknown Impact

IMPLEMENTATION REQUIREMENTS

- Capital Costs
- O&M Costs
- Maintenance
- Training

- High
- Medium
- Low



PROGRAM ELEMENTS

- New Development
- Residential
- Commercial Activities
- Industrial Activities
- Municipal Facilities
- Illegal Discharges

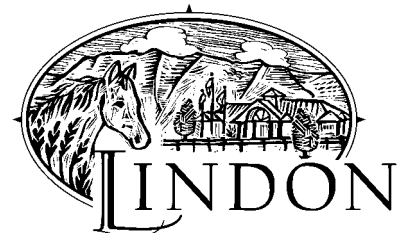

Adapted from Salt Lake County BMP Fact Sheet

DESCRIPTION:

Reduce the discharges of pollutants to stormwater from parking lot surfaces by conducting parking lot cleaning on a regular basis.

APPROACH:

- ▶ Restrict parking prior to and during sweeping.
- ▶ Establish frequency of sweeping based on anticipated need and observations of debris or sediment accumulation
- ▶ Increase sweeping frequency just before the rainy season.
- ▶ Lots that generate greater amounts of debris or sediment must be swept more frequently. These include lots associated with or adjacent to recreational, commercial, or industrial areas, or other areas of high vehicle or pedestrian traffic.
- ▶ Manually remove debris from corners or other areas of the parking lot that equipment cannot reach
- ▶ Keep accurate operation logs to track programs.
- ▶ Equipment selection can be key for this particular BMP. There are two types used, the mechanical broom sweepers (more effective at picking up large debris and cleaning wet streets), and the vacuum sweepers (more effective at removing fine particles and associated heavy metals). It may be useful to have the ability to use both kinds.

LIMITATIONS:

- ▶ Conventional sweepers are not able to remove oil and grease.
- ▶ Mechanical sweepers are not effective at removing finer sediments.
- ▶ Effectiveness may also be limited by parking lot conditions, presence of parked vehicles, presence of construction projects, climatic conditions and condition of curbs.

MAINTENANCE:

- ▶ Acquisition and maintenance of equipment is generally handled by the company hired to perform the sweeping/vacuuming.

TARGETED POLLUTANTS

- Sediment
- Nutrients
- Heavy Metals
- Toxic Materials
- Oxygen Demanding Substances
- Oil & Grease
- Floatable Materials
- Bacteria & Viruses

- High Impact
- Medium Impact
- Low or Unknown Impact

IMPLEMENTATION REQUIREMENTS

- Capital Costs
- O&M Costs
- Regulatory
- Training
- Staffing
- Administrative

- High Medium Low

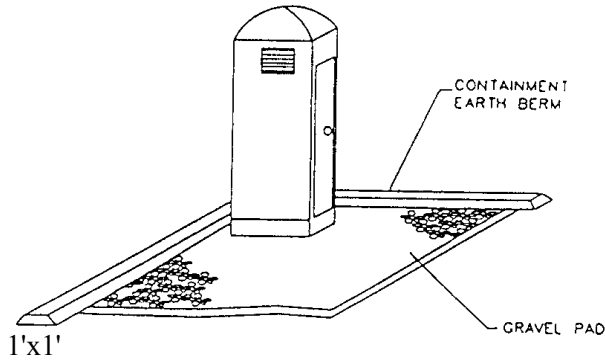

OBJECTIVES

- Housekeeping Practices
- Contain Waste
- Minimize Disturbed Areas
- Stabilize Disturbed Areas
- Protect Slopes/Channels
- Control Site Perimeter
- Control Internal Erosion



Adapted from Salt Lake County BMP Fact Sheet

DESCRIPTION:

Temporary on-site sanitary facilities for construction personnel.

APPLICATION:

All sites with no permanent sanitary facilities or where permanent facility is too far from activities.

INSTALLATION/APPLICATION CRITERIA:

- ▶ Locate portable toilets in convenient locations throughout the site.
- ▶ Prepare level, gravel surface and provide clear access to the toilets for servicing and for on-site personnel.
- ▶ Construct earth berm perimeter (See Earth Berm Barrier Information Sheet), control for spill/protection leak.

LIMITATIONS:

No limitations.

MAINTENANCE:

- ▶ Portable toilets should be maintained in good working order by licensed service with daily observation for leak detection.
- ▶ Regular waste collection should be arranged with licensed service.
- ▶ All waste should be deposited in sanitary sewer system for treatment with appropriate agency approval.

TARGETED POLLUTANTS

- Sediment
- Nutrients
- Toxic Materials
- Oil & Grease
- Floatable Materials
- Other Waste

- High Impact
- Medium Impact
- Low or Unknown Impact

IMPLEMENTATION REQUIREMENTS

- Capital Costs
- O&M Costs
- Maintenance
- Training

- High Medium Low

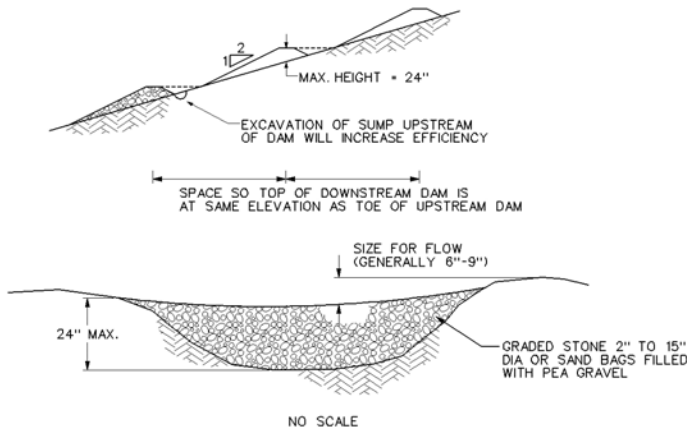

DESCRIPTION:

A small, temporary dam constructed across a drainage ditch to reduce velocity of concentrated storm water flows, thereby reducing the erosion of the ditch.

APPLICATION:

- ▶ Temporary drainage paths
- ▶ Permanent drainage ways not yet stabilized
- ▶ Existing drainage paths receiving increased flows due to construction

INSTALLATION/APPLICATION CRITERIA:

- ▶ Prepare location of dam by removing any debris and rough grading any irregularities in channel bottom
- ▶ Place rocks by hand or with appropriate machinery, do not dump
- ▶ Construct dam with center lower to pass design flow
- ▶ Construct 50% side slopes on dam

LIMITATIONS:

- ▶ Maximum recommended drainage area is 10 acres
- ▶ Maximum recommended height is 24"
- ▶ Do not use in running stream

MAINTENANCE:

- ▶ Inspect dams daily during prolonged rainfall, after each major rain event and at a minimum of once monthly.
- ▶ Remove any large debris and repair any damage to dam, channel or sideslopes
- ▶ Remove accumulated sediment when it reaches one half the height of the dam

OBJECTIVES

- Housekeeping Practices
- Contain Waste
- Minimize Disturbed Areas
- Stabilize Disturbed Areas
- Protect Slopes/Channels
- Control Site Perimeter
- Control Internal Erosion

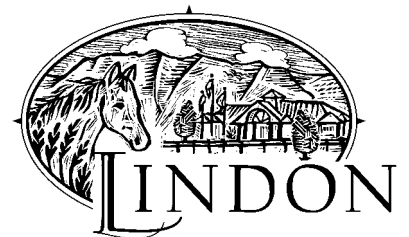

Adapted from Salt Lake County BMP Fact Sheet

TARGETED POLLUTANTS

- Sediment
- Nutrients
- Toxic Materials
- Oil & Grease
- Floatable Materials
- Other Waste

- High Impact
- Medium Impact
- Low or Unknown Impact

IMPLEMENTATION REQUIREMENTS

- Capital Costs
- O&M Costs
- Maintenance
- Training

- High Medium Low



DESCRIPTION:

Riprap is a permanent, erosion-resistant protective layer made of loose stones. It is intended to protect soil from erosion in areas of concentrated runoff. Riprap may also be used to stabilize slopes that are unstable because of seepage problems.

APPLICATION:

- ▶ Riprap is normally used at locations where erosive forces from water flow exceed the ability of the soil or vegetative cover to resist those forces.
- ▶ Riprap can be used for pipe outlet protection, channel lining, scour protection, etc.
- ▶ Riprap is commonly used for wave protection on lakes.

INSTALLATION/APPLICATION CRITERIA:

- ▶ For slopes steeper than 2:1, consider using materials other than riprap for erosion protection.
- ▶ If riprap is being planned for the bottom of a permanently flowing channel, the bottom can be modified to enhance fish habitat. This can be done by constructing riffles and pools which simulate natural conditions.
- ▶ When working within flowing streams, measures should be taken to prevent excessive turbidity and erosion during construction. Bypassing base flows or temporarily blocking base flows are two possible methods. Work should be done during a period of low flow.

In designing riprap consider the following:

- ▶ Use durable rock, such as granite, and a variety of rock sizes.
- ▶ The thickness of riprap layers should be at least 1.25 times the max. stone diameter.
- ▶ Filter material is usually required between riprap and the underlying soil surface.

LIMITATIONS:

- ▶ Riprap may be unstable on very steep slopes.
- ▶ The placement of a riprap in streams requires a state stream alteration permit.

MAINTENANCE:

- ▶ Riprap should be inspected annually and after major storms.
- ▶ If riprap has been damaged, repairs should be made promptly to prevent a progressive failure.
- ▶ If repairs are needed repeatedly at one location, the site should be evaluated to see if original design conditions have changed.

CONSIDERATIONS

- Soils
- Area Required
- Slope
- Water Availability
- Aesthetics
- Hydraulic Head
- Environmental Side Effects

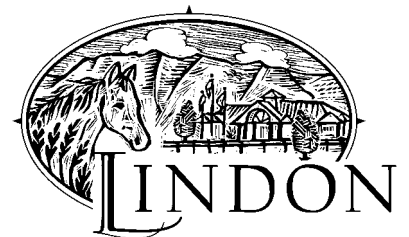

Adapted from Salt Lake County BMP Fact Sheet

TARGETED POLLUTANTS

- Sediment
- Nutrients
- Heavy Metals
- Toxic Materials
- Oxygen Demanding Substances
- Oil & Grease
- Floatable Materials
- Bacteria & Viruses

- High Impact
- Medium Impact
- Low or Unknown Impact

IMPLEMENTATION REQUIREMENTS

- Capital Costs
- O&M Costs
- Maintenance
- Training

- High Medium Low

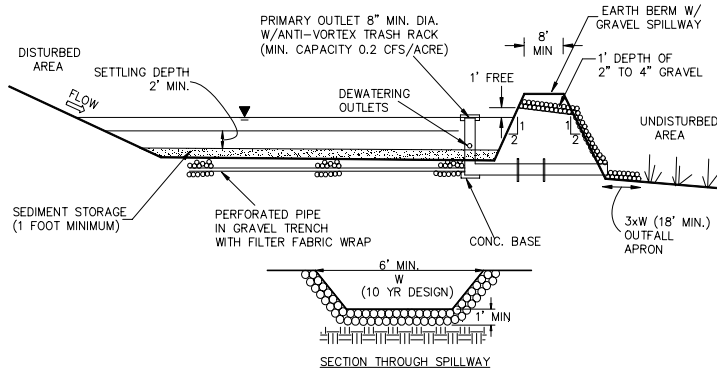

OBJECTIVES

- Housekeeping Practices
- Contain Waste
- Minimize Disturbed Areas
- Stabilize Disturbed Areas
- Protect Slopes/Channels
- Control Site Perimeter
- Control Internal Erosion

DESCRIPTION:

A pond created by excavation or construction of an embankment, and designed to retain or detain runoff sufficiently to allow excessive sediment to settle.

APPLICATION:

- ▶ At the outlet of all disturbed watersheds 10 acres or larger.
- ▶ At the outlet of smaller disturbed watersheds, as necessary.
- ▶ Where post construction detention basins will be located.

INSTALLATION/APPLICATION CRITERIA:

- ▶ Design basin for site specific location, maintain effective flow length 2 times width.
- ▶ Excavate basin or construct compacted berm containment, ensure no downgradient hazard if failure should occur. (Provide minimum of 67 cy. per acre of drainage area).
- ▶ Construct dewatering and outfall structure and emergency spillway with apron.

LIMITATIONS:

- ▶ Should be sized based on anticipated runoff, sediment loading and drainage area size.
- ▶ May require silt fence at outlet for entrapment of very fine silts and clays.
- ▶ May require safety fencing to prevent public access.
- ▶ Height restrictions for embankment regulated by Utah Division of Dam Safety.

MAINTENANCE:

- ▶ Inspect after each rainfall event and at a minimum of monthly.
- ▶ Repair any damage to berm, spillway or sidewalls.
- ▶ Remove accumulated sediment as it reaches 2/3 height of available storage.
- ▶ Check outlet for sedimentation/erosion of downgradient area and remediate as necessary. Install silt fence if sedimentation apparent.

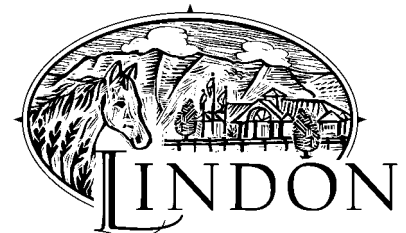

Adapted from Salt Lake County BMP Fact Sheet

TARGETED POLLUTANTS

- Sediment
- Nutrients
- Toxic Materials
- Oil & Grease
- Floatable Materials
- Other Waste

- High Impact
- Medium Impact
- Low or Unknown Impact

IMPLEMENTATION REQUIREMENTS

- Capital Costs
- O&M Costs
- Maintenance
- Training

- High
- Medium
- Low

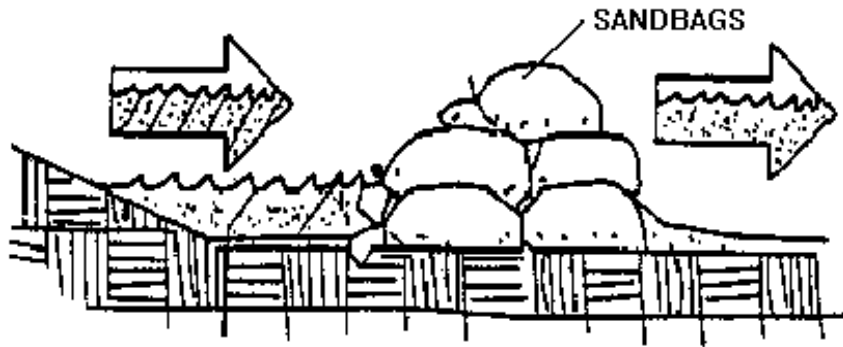

DESCRIPTION:

Stacking sand bags along a level contour creates a barrier which detains sediment-laden water, ponding water upstream of the barrier and promoting sedimentation.

APPLICATION:

- ▶ Along the perimeter of the site.
- ▶ May be used in drainage areas up to 5 acres.
- ▶ Along streams and channels
- ▶ Across swales with small catchments.
- ▶ Around temporary spoil areas.
- ▶ Below the toe of a cleared slope.

INSTALLATION/APPLICATION CRITERIA:

- ▶ Install along a level contour.
- ▶ Base of sand bag barrier should be at least 48 inches wide.
- ▶ Height of sand bag barrier should be at least 18 inches high.
- ▶ 4 inch PVC pipe may be installed between the top layer of sand bags to drain large flood flows.
- ▶ Provide area behind barrier for runoff to pond and sediment to settle.
- ▶ Place below the toe of a slope.

LIMITATIONS:

- ▶ Sand bags are more expensive than other barriers, but also more durable.
- ▶ Burlap should not be used.

MAINTENANCE:

- ▶ Inspect after each rain.
- ▶ Reshape or replace damaged sand bags immediately.
- ▶ Replace sediment when it reaches six inches in depth.

OBJECTIVES

- Housekeeping Practices
- Contain Waste
- Minimize Disturbed Areas
- Stabilize Disturbed Areas
- Protect Slopes/Channels
- Control Site Perimeter
- Control Internal Erosion

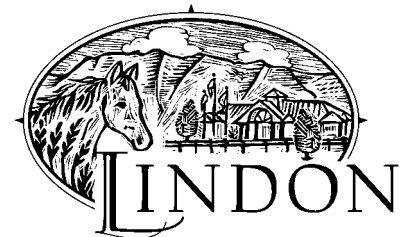

Adapted from Salt Lake County BMP Fact Sheet

TARGETED POLLUTANTS

- Sediment
- Nutrients
- Toxic Materials
- Oil & Grease
- Floatable Materials
- Other Waste

- High Impact
- Medium Impact
- Low or Unknown Impact

IMPLEMENTATION REQUIREMENTS

- Capital Costs
- O&M Costs
- Maintenance
- Training

- High
- Medium
- Low

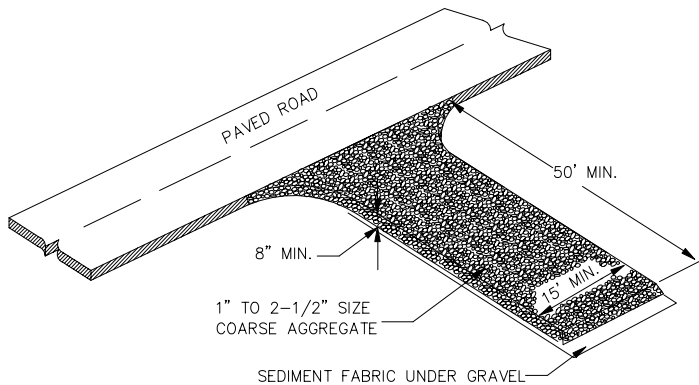

OBJECTIVES

- Housekeeping Practices
- Contain Waste
- Minimize Disturbed Areas
- Stabilize Disturbed Areas
- Protect Slopes/Channels
- Control Site Perimeter
- Control Internal Erosion

DESCRIPTION:

A stabilized pad of crushed stone located where construction traffic enters or leaves the site from or to paved surface. The area can be used to spray off vehicles before they leave the site.

APPLICATIONS:

At any point of ingress or egress at a construction site where adjacent traveled way is paved. Generally applies to sites over 2 acres unless special conditions exist.

INSTALLATION/APPLICATION CRITERIA:

- ▶ Clear and grub area and grade to provide maximum slope of 2%.
- ▶ Compact subgrade and place filter fabric if desired (recommended for entrances to remain for more than 3 months).
- ▶ Place coarse aggregate, 1 to 2-1/2 inches in size, to a minimum depth of 8 inches.
- ▶ Provide water to the area that can be used to spray off vehicles as needed to prevent the tracking of mud off of the construction site. This may not be needed during dry periods of work, but is needed when construction is proceeding under wet conditions.
- ▶ Provide berming as needed to prevent sediment laden wash water from entering storm water facilities or other water bodies, or leaving the site.

LIMITATIONS:

- ▶ Requires periodic top dressing with additional stones.
- ▶ Should be used in conjunction with street sweeping on adjacent public right-of-way.
- ▶ Must be situated such that waste water does not run off site.

MAINTENANCE:

- ▶ Inspect daily for loss of gravel or sediment buildup.
- ▶ Inspect adjacent roadway for sediment deposit and clean by shoveling and sweeping.
- ▶ Repair entrance and replace gravel as required to maintain control in good working condition.
- ▶ Expand stabilized area as required to accommodate traffic and prevent erosion at driveways.

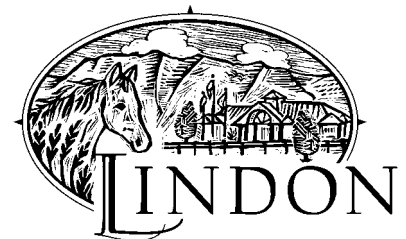

Adapted from Salt Lake County BMP Fact Sheet

TARGETED POLLUTANTS

- Sediment
- Nutrients
- Toxic Materials
- Oil & Grease
- Floatable Materials
- Other Waste

- High Impact
- Medium Impact
- Low or Unknown Impact

IMPLEMENTATION REQUIREMENTS

- Capital Costs
- O&M Costs
- Maintenance
- Training

- High
- Medium
- Low

BMP: Sediment Control on Small Construction Sites

SCSCS

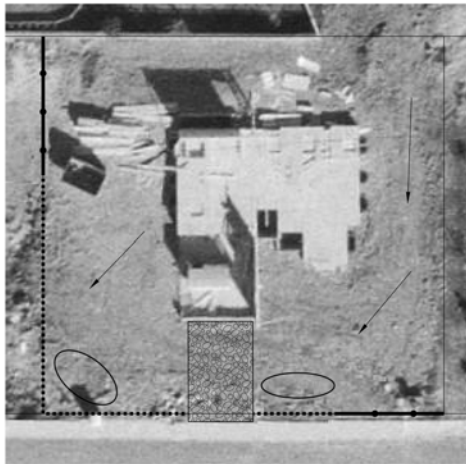

APPLICATIONS

- Manufacturing
- Material Handling
- Vehicle Maintenance
- Construction
- Commercial Activities
- Roadways
- Waste Containment
- Housekeeping Practices

DESCRIPTION:

Control the perimeter, vehicular access, and the delivery of materials to small construction sites so that sediment, landscaping materials and other construction debris is not in the street. This BMP is intended to be applied to residential construction sites and small nonresidential sites.

APPROACH:

- Prior to any building construction on a site, identify the point of access to the property. This should generally be the location of the future driveway. Fence the remainder of the street frontage of the property, as well as side lot lines (as far as necessary to prevent access) with temporary fencing (silt fence may be used where silt fence is needed). This fencing is to remain in place until all construction or landscape material deliveries are complete. **No access is to be made at any point other than the designated point of access.**
- Control the perimeter of the site so that sediment-laden storm water does not leave the site during construction. This may involve sediment control measures such as silt fences, drainage swales or berms, straw or hay bale barriers, or rock check dams.
- Either utilize the curb cut or leave the curb, gutter and sidewalk in place (and replace it if needed when work is complete). **Do not place anything in the gutter, including dirt ramps.**
- Excavate for and place a bed of gravel or drain rock the full width of the future driveway (16' minimum), a distance of 32 feet back from the back of sidewalk. Place the rock to the depth necessary to prevent material delivery vehicles from contacting the on-site soils.
- At the proper time, the gravel or rock bed can be modified to serve as the base for concrete driveway placement. At that point, the concrete driveway will prevent delivery and other vehicles from coming into contact with on-site soils.

LIMITATIONS:

- It may be necessary to pump concrete to locations away from the bed of gravel or rock.
- Parking of workers' vehicles may require that the bed of gravel or rock be enlarged to make space for vehicle parking that keeps the vehicles from contacting the on-site soils.
- Builders, subcontractors, material suppliers, vendors and other visitors to the site must be educated to adhere to the practices outlined.
- Landscaping and construction materials must be placed on the lot, not the street or walk.

MAINTENANCE:

- Repair fencing as needed to maintain control of access.
- Repair sediment control measures as needed during construction.
- Replenish and dress up the gravel/rock area as needed during the course of construction.
- Any tracking of soil onto the adjacent street indicates inadequate performance of this BMP. Remove soil tracked onto the street at the end of any day that it occurs and take corrective measures to prevent soil tracking onto the street from recurring.

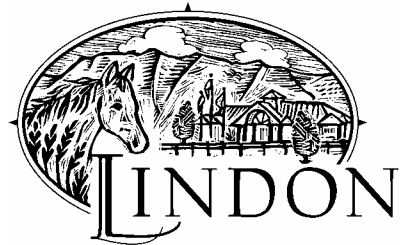

TARGETED POLLUTANTS

- Sediment
- Nutrients
- Heavy Metals
- Toxic Materials
- Oxygen Demanding Substances
- Oil & Grease
- Floatable Materials
- Bacteria & Viruses

- High Impact
- Medium Impact
- Low or Unknown Impact

IMPLEMENTATION REQUIREMENTS

- Capital Costs
- O&M Costs
- Maintenance
- Training

- High
- Medium
- Low

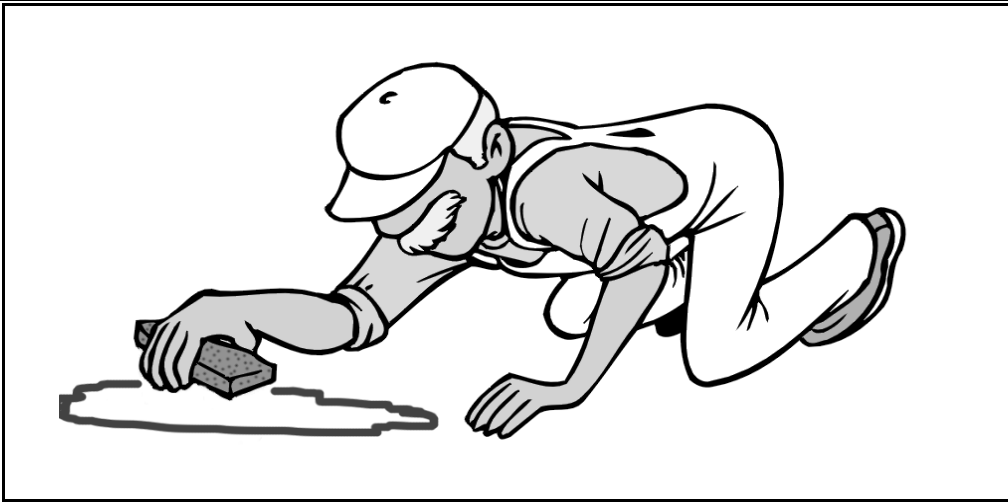

OBJECTIVES

- Housekeeping Practices
- Contain Waste
- Minimize Disturbed Areas
- Stabilize Disturbed Areas
- Protect Slopes/Channels
- Control Site Perimeter
- Control Internal Erosion



Adapted from Salt Lake County BMP Fact Sheet

DESCRIPTION:

Practices to clean-up leakage/spillage of on-site materials that may be harmful to receiving waters.

APPLICATION:

All sites

GENERAL:

- ▶ Store controlled materials within a storage area.
- ▶ Educate personnel on prevention and clean-up techniques.
- ▶ Designate an Emergency Coordinator responsible for employing preventative practices and for providing spill response.
- ▶ Maintain a supply of clean-up equipment on-site and post a list of local response agencies with phone numbers.

METHODS:

- ▶ Clean-up spills/leaks immediately and remediate cause.
- ▶ Use as little water as possible. **NEVER HOSE DOWN OR BURY SPILL CONTAMINATED MATERIAL.**
- ▶ Use rags or absorbent material for clean-up. Excavate contaminated soils. Dispose of clean-up material and soil as hazardous waste.
- ▶ Document all spills with date, location, substance, volume, actions taken and other pertinent data.
- ▶ Contact local Fire Department and State Division of Environmental Response and Remediation (Phone #801-536-4100) for any spill of reportable quantity.

TARGETED POLLUTANTS

- Sediment
- Nutrients
- Toxic Materials
- Oil & Grease
- Floatable Materials
- Other Waste

- High Impact
- Medium Impact
- Low or Unknown Impact

IMPLEMENTATION REQUIREMENTS

- Capital Costs
- O&M Costs
- Maintenance
- Training

- High Medium Low

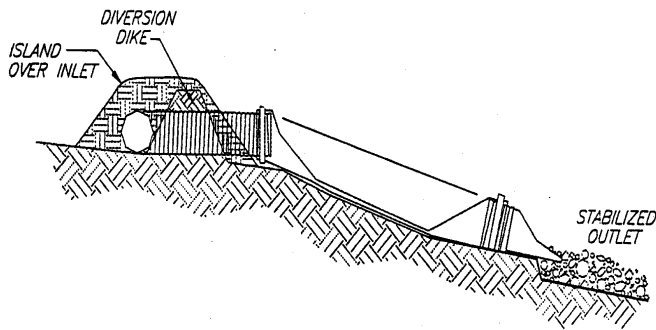

DESCRIPTION:

A temporary pipe or lined channel that drains the top of a slope to a stable discharge point at the bottom of a slope without causing erosion.

APPLICATIONS:

- ▶ Where concentrated flow of surface runoff must be conveyed down a slope in order to prevent erosion.
- ▶ Drainage for top slope diversion dikes or swales.
- ▶ Emergency spillway for a sediment basin.
- ▶ Drainage for top of cut/fill slopes where water can accumulate.

INSTALLATION/APPLICATION CRITERIA:

- ▶ Secure inlet and surround with dikes to prevent gully erosion, and anchor pipe to slope.
- ▶ Size to convey at least the peak of a 10-year, storm event.
- ▶ Stabilize outlet. (See Outlet Protection BMP).

LIMITATIONS:

- ▶ Maximum drainage area per slope drain is 5 acres.
- ▶ Clogged slope drains will force water around the pipe and cause slope erosion.
- ▶ Dissipation of high flow velocities at the pipe outlet is required to avoid downstream erosion.
- ▶ Failure can result in flooding and severe erosion.

MAINTENANCE:

- ▶ Structure must be inspected weekly and after storms.
- ▶ Inlet must be free of undercutting and no water should circumvent the entry.
- ▶ Outlet should not produce erosion; velocity dissipaters must be maintained.
- ▶ Pipe anchors must be checked to ensure that the pipe remains anchored to the slope.

OBJECTIVES

- Housekeeping Practices
- Contain Waste
- Minimize Disturbed Areas
- Stabilize Disturbed Areas
- Protect Slopes/Channels
- Control Site Perimeter
- Control Internal Erosion

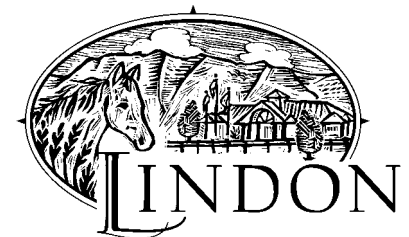

Adapted from Salt Lake County BMP Fact Sheet

TARGETED POLLUTANTS

- Sediment
- Nutrients
- Toxic Materials
- Oil & Grease
- Floatable Materials
- Other Waste

- High Impact
- Medium Impact
- Low or Unknown Impact

IMPLEMENTATION REQUIREMENTS

- Capital Costs
- O&M Costs
- Maintenance
- Training

- High
- Medium
- Low

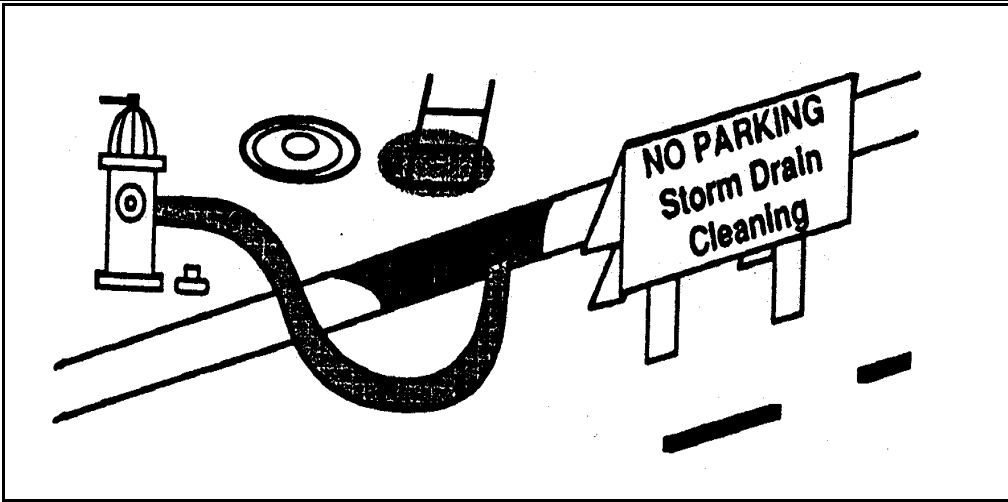

DESCRIPTION:

A storm drain is "flushed" with water to suspend and remove deposited materials. Flushing is particularly beneficial for storm drain pipes with grades too flat to be self-cleansing. Flushing helps ensure pipes convey design flow and remove pollutants from the storm drain system.

APPROACH:

- ▶ Locate reaches of storm drain with deposit problems and develop a flushing schedule that keeps the pipe clear of excessive buildup.
- ▶ Whenever possible, flushed effluent should be collected, decanted, evaporated, and disposed of in a landfill.

LIMITATIONS:

- ▶ Most effective in small diameter pipes (36-inch diameter pipe or less, depending on water supply and sediment collection capacity).
- ▶ Water source must be available.
- ▶ May have difficulty finding downstream area to collect sediments.
- ▶ Requires liquid/sediment disposal.

PROGRAM ELEMENTS

- New Development
- Residential
- Commercial Activities
- Industrial Activities
- Municipal Facilities
- Illegal Discharges

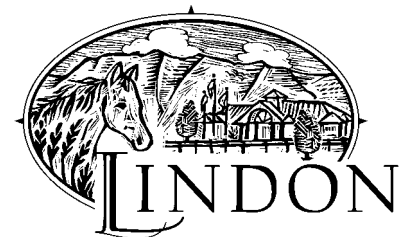

Adapted from Salt Lake County BMP Fact Sheet

TARGETED POLLUTANTS

- Sediment
- Nutrients
- Heavy Metals
- Toxic Materials
- Oxygen Demanding Substances
- Oil & Grease
- Floatable Materials
- Bacteria & Viruses

- High Impact
- Medium Impact
- Low or Unknown Impact

IMPLEMENTATION REQUIREMENTS

- Capital Costs
- O&M Costs
- Regulatory
- Training
- Staffing
- Administrative

- High Medium Low

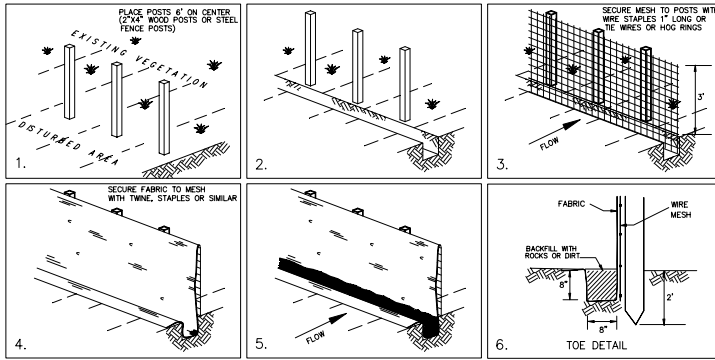

DESCRIPTION:

A temporary sediment barrier consisting of entrenched filter fabric stretched across and secured to supporting posts.

APPLICATION:

- ▶ Perimeter control: place barrier at downgradient limits of disturbance
- ▶ Sediment barrier: place barrier at toe of slope or soil stockpile
- ▶ Protection of existing waterways: place barrier near top of stream bank
- ▶ Inlet protection: place fence surrounding catchbasins

INSTALLATION/APPLICATION CRITERIA:

- ▶ Place posts 6 feet apart on center along contour (or use preassembled unit) and drive 2 feet minimum into ground. Excavate an anchor trench immediately upgradient of posts.
- ▶ Secure wire mesh (14 gage min. With 6 inch openings) to upslope side of posts. Attach with heavy duty 1 inch long wire staples, tie wires or hog rings.
- ▶ Cut fabric to required width, unroll along length of barrier and drape over barrier. Secure fabric to mesh with twine, staples, or similar, with trailing edge extending into anchor trench.
- ▶ Backfill trench over filter fabric to anchor.

LIMITATIONS:

- ▶ Recommended maximum drainage area of 0.5 acre per 100 feet of fence
- ▶ Recommended maximum upgradient slope length of 150 feet
- ▶ Recommended maximum uphill grade of 2:1 (50%)
- ▶ Recommended maximum flow rate of 0.5 cfs
- ▶ Ponding should not be allowed behind fence

MAINTENANCE:

- ▶ Inspect immediately after any rainfall and at least daily during prolonged rainfall.
- ▶ Look for runoff bypassing ends of barriers or undercutting barriers.
- ▶ Repair or replace damaged areas of the barrier and remove accumulated sediment.
- ▶ Reanchor fence as necessary to prevent shortcutting.
- ▶ Remove accumulated sediment when it reaches 1/2 the height of the fence.

OBJECTIVES

- Housekeeping Practices
- Contain Waste
- Minimize Disturbed Areas
- Stabilize Disturbed Areas
- Protect Slopes/Channels
- Control Site Perimeter
- Control Internal Erosion



Adapted from Salt Lake County BMP Fact Sheet

TARGETED POLLUTANTS

- Sediment
- Nutrients
- Toxic Materials
- Oil & Grease
- Floatable Materials
- Other Waste

- High Impact
- Medium Impact
- Low or Unknown Impact

IMPLEMENTATION REQUIREMENTS

- Capital Costs
- O&M Costs
- Maintenance
- Training

- High
- Medium
- Low

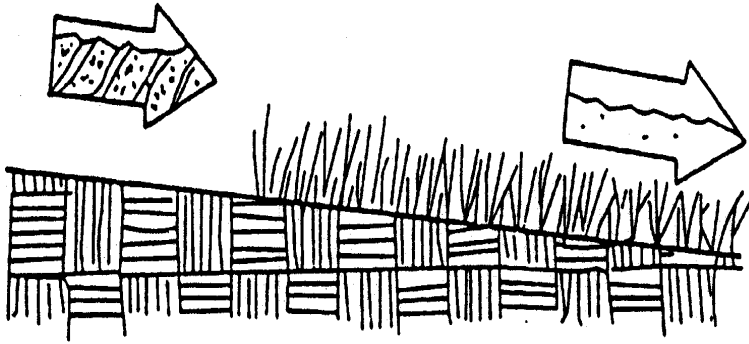

DESCRIPTION:

Seeding of grass and plantings of trees, shrubs, vines and ground covers provide long-term stabilization of soil. Grasses can be planted for temporary stabilization.

APPLICATION:

- ▶ Appropriate for site stabilization both during construction and post-construction.
- ▶ Any graded/cleared areas where construction activities have ceased.
- ▶ Open space cut and fill areas.
- ▶ Steep slopes, spoil piles, vegetated swales, landscape corridors, stream banks.

INSTALLATION/APPLICATION CRITERIA:

Type of vegetation, site and seedbed preparation, planting time, fertilization and water requirements should be considered for each application.

Grasses:

- ▶ Ground preparation: fertilize and mechanically stabilize the soil.
- ▶ Tolerant of short-term temperature extremes and waterlogged soil composition.
- ▶ Appropriate soil conditions: shallow soil base, good drainage, slope 2:1 or flatter.
- ▶ Mowing, irrigating, and fertilizing are vital for promoting vigorous grass growth.

Trees and Shrubs:

- ▶ Selection criteria: vigor, species, size, shape & wildlife food source.
- ▶ Soil conditions: select species appropriate for soil, drainage & acidity.
- ▶ Other factors: wind/exposure, temperature extremes, and irrigation needs.

Vines and Ground Covers:

- ▶ Ground preparation: lime and fertilizer preparation.
- ▶ Use proper seeding rates.
- ▶ Appropriate soil conditions: drainage, acidity and slopes.
- ▶ Generally avoid species requiring irrigation.

LIMITATIONS:

- ▶ Permanent and temporary vegetation may not be appropriate in dry periods without irrigation.
- ▶ Fertilizer requirements may have potential to create stormwater pollution.

MAINTENANCE:

- ▶ Shrubs and trees must be adequately watered and fertilized and if needed pruned.
- ▶ Grasses may need to be watered and mowed.

OBJECTIVES

- Housekeeping Practices
- Contain Waste
- Minimize Disturbed Areas
- Stabilize Disturbed Areas
- Protect Slopes/Channels
- Control Site Perimeter
- Control Internal Erosion

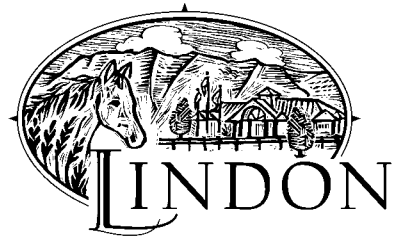

Adapted from Salt Lake County BMP Fact Sheet

TARGETED POLLUTANTS

- Sediment
- Nutrients
- Toxic Materials
- Oil & Grease
- Floatable Materials
- Other Waste

- High Impact
- Medium Impact
- Low or Unknown Impact

IMPLEMENTATION REQUIREMENTS

- Capital Costs
- O&M Costs
- Maintenance
- Training

- High Medium Low

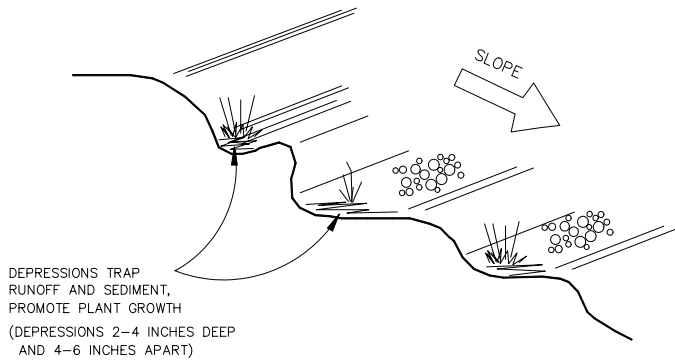

DESCRIPTION:

Rough preparation of working areas leaving depressions and uneven surface. Depressions should be done parallel to contours.

APPLICATION:

Surface roughening is appropriate for all construction that will not be receiving impervious cover within 14 days and that will be exposed less than 60 days (seed areas to be open in excess of 60 days).

INSTALLATION/APPLICATION CRITERIA:

- ▶ Surface should be left in rough condition during initial earthwork activity.
- ▶ Surfaces that have become smoothed or compacted due to equipment traffic should be roughened by use of disks, spring harrows, teeth on front end loader, or similar, operating along the contours of the slope. Tracking (by crawler tractor driving up and down slope) may also be used to provide depressions parallel to contours.
- ▶ Avoid compaction of soils during roughening as this inhibits plant growth and promotes storm water runoff. Limit tracked machinery to sandy soil.
- ▶ Seed or mulch areas to be exposed in excess of 60 days.
- ▶ Employ dust controls (See Dust Control BMP Fact Sheet).

LIMITATIONS:

- ▶ Will not withstand heavy rainfall.
- ▶ Slopes steeper than 2:1 (50%) should be benched (See Benching BMP Fact Sheet).

MAINTENANCE:

- ▶ Inspect following any storm event and at a minimum of weekly.
- ▶ If erosion in the form of rills (small waterways formed by runoff) is evident, perform machine roughening of area.
- ▶ For vegetated slopes reseed areas that are bare or have been reworked.

OBJECTIVES

- Housekeeping Practices
- Contain Waste
- Minimize Disturbed Areas
- Stabilize Disturbed Areas
- Protect Slopes/Channels
- Control Site Perimeter
- Control Internal Erosion

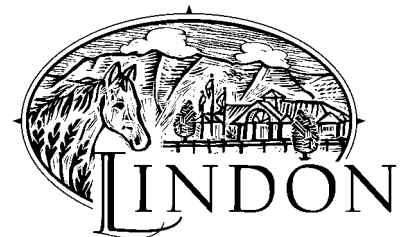

Adapted from Salt Lake County BMP Fact Sheet

TARGETED POLLUTANTS

- Sediment
- Nutrients
- Toxic Materials
- Oil & Grease
- Floatable Materials
- Other Waste

- High Impact
- Medium Impact
- Low or Unknown Impact

IMPLEMENTATION REQUIREMENTS

- Capital Costs
- O&M Costs
- Maintenance
- Training

- High Medium Low

BMP: Sediment Trap

ST

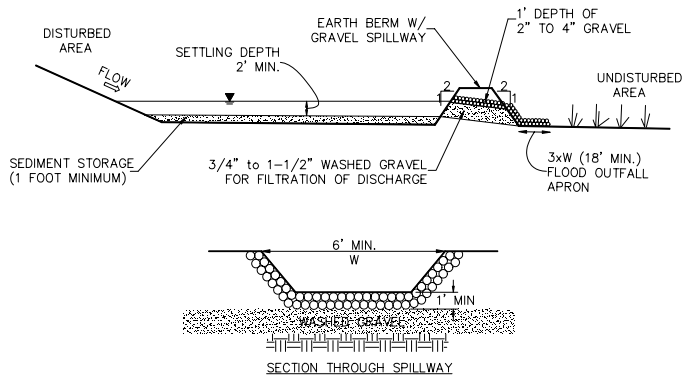

OBJECTIVES

- Housekeeping Practices
- Contain Waste
- Minimize Disturbed Areas
- Stabilize Disturbed Areas
- Protect Slopes/Channels
- Control Site Perimeter
- Control Internal Erosion

DESCRIPTION:

A sediment trap is a small excavated or bermed area where runoff from small drainage areas is detained and sediment can settle.

APPLICATION:

- ▶ Temporary control for runoff from disturbed areas of less than 3 acres.
- ▶ Temporary control for discharge from diversion dike, surface benching, or other temporary drainage measures.

INSTALLATION/APPLICATION CRITERIA:

- ▶ Design basin for site specific location.
- ▶ Excavate basin or construct compacted berm containment.
- ▶ Construct outfall spillway with apron.
- ▶ Provide downstream silt fence if necessary.

LIMITATIONS:

- ▶ Should be sized based on anticipated runoff, sediment loading and drainage area size.
- ▶ May require silt fence at outlet for entrapment of very fine silts and clays.

MAINTENANCE:

- ▶ Inspect after each rainfall event and at a minimum of monthly.
- ▶ Repair any damage to berm, spillway or sidewalls.
- ▶ Remove accumulated sediment as it reaches 2/3 height of available storage.
- ▶ Check outlet for sedimentation/erosion of downgradient area and remediate as necessary. Install silt fence if sedimentation apparent.



Adapted from Salt Lake County BMP Fact Sheet

TARGETED POLLUTANTS

- Sediment
- Nutrients
- Toxic Materials
- Oil & Grease
- Floatable Materials
- Other Waste

- High Impact
- Medium Impact
- Low or Unknown Impact

IMPLEMENTATION REQUIREMENTS

- Capital Costs
- O&M Costs
- Maintenance
- Training

- High
- Medium
- Low

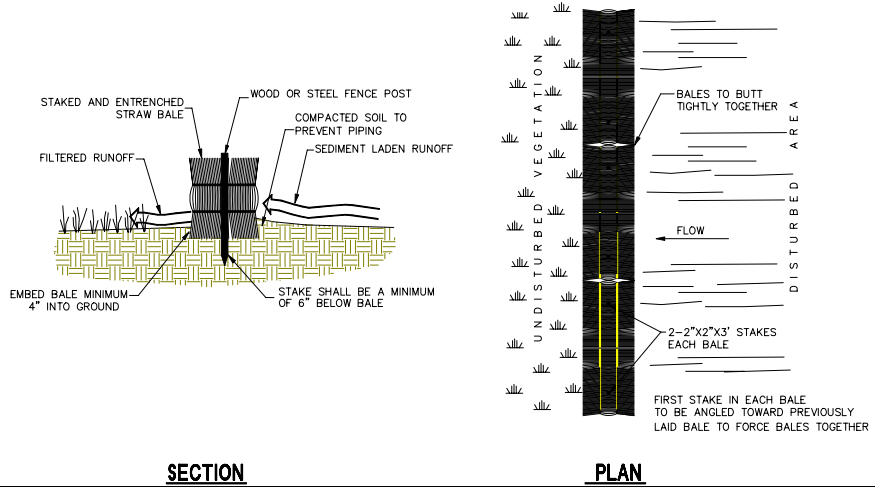

OBJECTIVES

- Housekeeping Practices
- Contain Waste
- Minimize Disturbed Areas
- Stabilize Disturbed Areas
- Protect Slopes/Channels
- Control Site Perimeter
- Control Internal Erosion

DESCRIPTION:

Temporary sediment barrier consisting of a row of entrenched and anchored straw bales.

APPLICATION:

- ▶ Perimeter Control: place barrier at downgradient limits of disturbance.
- ▶ Sediment barrier: place barrier at toe of slope or soil stockpile.
- ▶ Protection of existing waterways: place barrier near top of stream bank.
- ▶ Inlet Protection.

INSTALLATION/APPLICATION CRITERIA:

- ▶ Excavate a 4-inch minimum deep trench along contour line, i.e. parallel to slope, removing all grass and other material that may allow underflow.
- ▶ Place bales in trench with ends tightly abutting, fill any gaps by wedging loose straw into openings.
- ▶ Anchor each bale with 2 stakes driven flush with the top of the bale.
- ▶ Backfill around bale and compact to prevent piping, backfill on uphill side to be built up 4-inches above ground at the barrier.

LIMITATIONS:

- ▶ Recommended maximum area of 0.5 acre per 100 feet of barrier
- ▶ Recommended maximum upgradient slope length of 150 feet
- ▶ Recommended maximum uphill grade of 2:1 (50%)

MAINTENANCE:

- ▶ Inspect immediately after any rainfall and at least daily during prolonged rainfall.
- ▶ Look for runoff bypassing ends of barriers or undercutting barriers.
- ▶ Repair or replace damaged areas of the barrier and remove accumulated sediment.
- ▶ Realign bales as necessary to provide continuous barrier and fill gaps.
- ▶ Recompress soil around barrier as necessary to prevent piping.

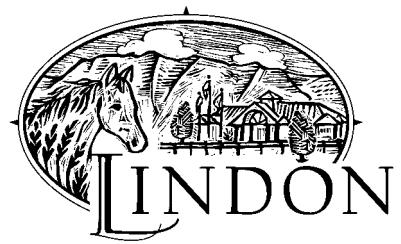

TARGETED POLLUTANTS

- Sediment
- Nutrients
- Toxic Materials
- Oil & Grease
- Floatable Materials
- Other Waste

- High Impact
- Medium Impact
- Low or Unknown Impact

IMPLEMENTATION REQUIREMENTS

- Capital Costs
- O&M Costs
- Maintenance
- Training

- High
- Medium
- Low

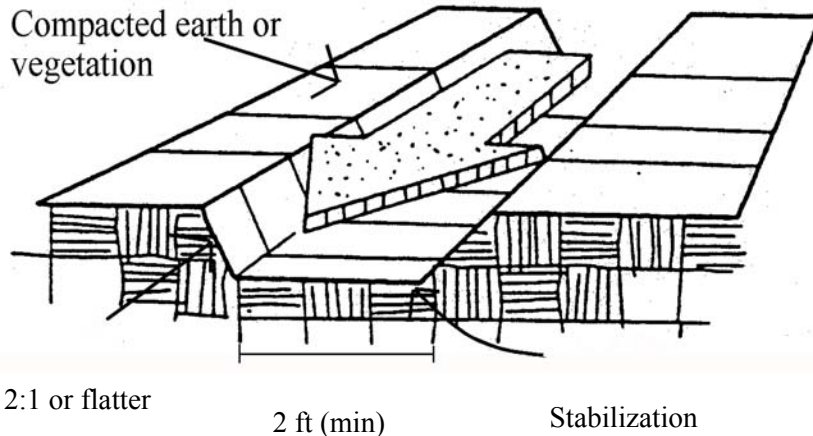

OBJECTIVES

- Housekeeping Practices
- Contain Waste
- Minimize Disturbed Areas
- Stabilize Disturbed Areas
- Protect Slopes/Channels
- Control Site Perimeter
- Control Internal Erosion

DESCRIPTION:

Temporary drains and swales are used to divert off-site runoff around the construction site, divert runoff from stabilized areas around disturbed areas, and direct runoff into sediment.

APPLICATIONS:

- ▶ Temporary drains and swales are appropriate for diverting any upslope runoff around unstabilized or disturbed areas of the construction site.
- ▶ Prevent slope failures. Prevent damage to adjacent property. Prevents erosion and transport of sediments into water ways. Increases the potential for infiltration. Diverts sediment-laden runoff into sediment basins or traps.

INSTALLATION/APPLICATION:

- ▶ Temporary drainage swales will effectively convey runoff and avoid erosion if built properly:
- ▶ Size temporary drainage swales using local drainage design criteria. A permanent drainage channel must be designed by a professional engineer (see the local drainage design criteria for proper design).
- ▶ At a minimum, the drain/swale should conform to predevelopment drainage patterns and capacities.
- ▶ Construct the drain/swale with an uninterrupted, positive grade to a stabilized outlet. Provide erosion protection or energy dissipation measures if the flow out of the drain or swale can reach an erosive velocity.

LIMITATIONS:

- ▶ Temporary drains and swales or any other diversion of runoff should not adversely impact upstream or downstream properties.
- ▶ Temporary drains and swales must conform to local floodplain management requirements.

MAINTENANCE:

- ▶ Inspect weekly and after each rain.
- ▶ Repair any erosion immediately.
- ▶ Remove sediment which builds up in the swale and restricts its flow capacity.



Adapted from Salt Lake County BMP Fact Sheet

TARGETED POLLUTANTS

- Sediment
- Nutrients
- Toxic Materials
- Oil & Grease
- Floatable Materials
- Other Waste

- High Impact
- Medium Impact
- Low or Unknown Impact

IMPLEMENTATION REQUIREMENTS

- Capital Costs
- O&M Costs
- Maintenance
- Training

- High Medium Low

BMP: Temporary and Permanent Seeding

TPS



DEFINITION:

Temporary seeding - establishment of short term cover by application of rapidly germinating seed mix (alternatively hydroseeding may be utilized).

Permanent seeding - establishment of final term cover by application of perennial seed mix (alternatively sod may be utilized).

APPLICATION:

Disturbed areas that are at final grade and which will not be disturbed by continuing activities on site. Also areas that are not at final grade but which will be left untouched in excess of one year.

RECOMMENDED SEED MIX:

The recommended seed mix will be dependent on site specific information such as elevation, exposure, soils, water available and topography. Check with the County Extension Service for recommended mixes for site specific conditions:

Utah State University Extension Service
51 South University Avenue, Suite 206
Provo, Utah 84601
phone (801) 370-8460

LIMITATIONS:

- ▶ Limited to areas that will not be subject to traffic or high usage.
- ▶ May require irrigation and fertilizer which creates potential for impacting runoff quality.
- ▶ May only be applied during appropriate planting season, temporary cover required until that time.

INSTALLATION:

- ▶ Roughen soil to a depth of 2 inches. Add fertilizer, manure, topsoil as necessary.
- ▶ Evenly distribute seed using a commonly accepted method such as broadcast seeding, drilling or hydroseeding.
- ▶ Use a seed mix appropriate for soil and location that will provide rapid germination and growth. Check with County Extension Service for recommended mix and application rate.
- ▶ Cover area with mulch if required due to steep slopes or unsuitable weather conditions.

MAINTENANCE:

- ▶ Provide irrigation as required to establish growth and to maintain plant cover through duration of project.
- ▶ Reseed as necessary to provide 75% coverage
- ▶ Remediate any areas damaged by erosion or traffic.
- ▶ When 75% coverage is achieved inspect monthly for damage and remediate as necessary.

OBJECTIVES

- Housekeeping Practices
- Contain Waste
- Minimize Disturbed Areas
- Stabilize Disturbed Areas
- Protect Slopes/Channels
- Control Site Perimeter
- Control Internal Erosion

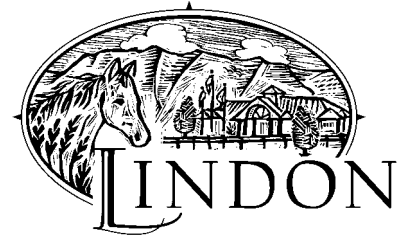

Adapted from Salt Lake County BMP Fact Sheet

TARGETED POLLUTANTS

- Sediment
- Nutrients
- Toxic Materials
- Oil & Grease
- Floatable Materials
- Other Waste

- High Impact
- Medium Impact
- Low or Unknown Impact

IMPLEMENTATION REQUIREMENTS

- Capital Costs
- O&M Costs
- Maintenance
- Training

- High Medium Low

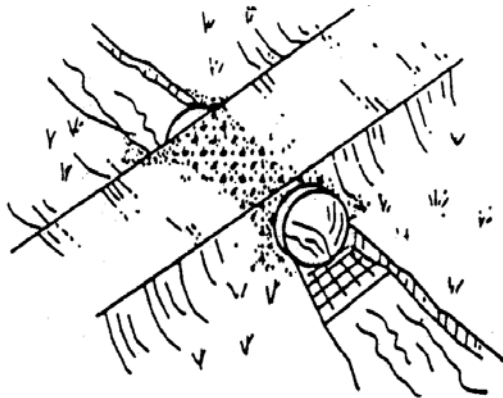

DESCRIPTION:

A temporary access stream crossing is a temporary culvert, ford or bridge placed across a waterway to provide access for construction purposes for a period of less than one year. Temporary access crossings are not intended to be used to maintain traffic for the general public.

APPLICATIONS:

Temporary stream crossings should be installed at all designated crossings of perennial and intermittent streams on the construction site, as well as for dry channels which may be significantly eroded by construction traffic.

INSTALLATION/APPLICATION:

Requires knowledge of stream flows and soil strength and should be designed under the direction of a Utah registered engineer with knowledge of both hydraulics and construction loading requirements for structures.

LIMITATIONS:

- ▶ May be expensive for a temporary improvement.
- ▶ Requires other BMP's to minimize soil disturbance during installation and removal.
- ▶ Fords should only be used in dry weather.
- ▶ A Stream Alteration Permit may be required, contact the Utah Division of Water Rights before implementation.

MAINTENANCE:

- ▶ Inspect weekly and after each significant rainfall, including assessment of foundations.
- ▶ Periodically remove silt from crossings.
- ▶ Replace lost aggregated from inlets and outlets of culverts.

OBJECTIVES

- Housekeeping Practices
- Contain Waste
- Minimize Disturbed Areas
- Stabilize Disturbed Areas
- Protect Slopes/Channels
- Control Site Perimeter
- Control Internal Erosion

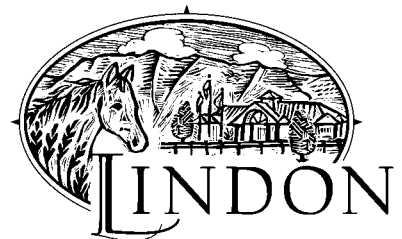

Adapted from Salt Lake County BMP Fact Sheet

TARGETED POLLUTANTS

- Sediment
- Nutrients
- Toxic Materials
- Oil & Grease
- Floatable Materials
- Other Waste

- High Impact
- Medium Impact
- Low or Unknown Impact

IMPLEMENTATION REQUIREMENTS

- Capital Costs
- O&M Costs
- Maintenance
- Training

- High Medium Low

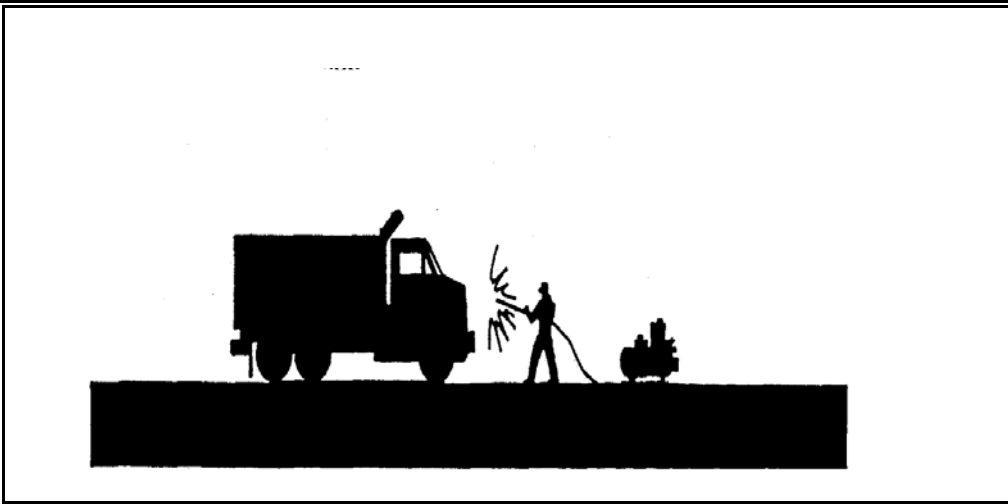

OBJECTIVES

- Housekeeping Practices
- Contain Waste
- Minimize Disturbed Areas
- Stabilize Disturbed Areas
- Protect Slopes/Channels
- Control Site Perimeter
- Control Internal Erosion



Adapted from Salt Lake County BMP Fact Sheet

DESCRIPTION:

Prevent or reduce the discharge of pollutants to storm water from vehicle and equipment cleaning by using off-site facilities, washing in designated, contained areas only, eliminating discharges to the storm drain by infiltrating or recycling the wash water, and/or training employees and subcontractors.

INSTALLATION/APPLICATION:

- ▶ Use off-site commercial washing businesses as much as possible. Washing vehicles and equipment outdoors or in areas where wash water flows onto paved surfaces or into drainage pathways can pollute storm water. If you wash a large number of vehicles or pieces of equipment, consider conducting this work at an off-site commercial business. These businesses are better equipped to handle and dispose of the wash waters properly. Performing this work off-site can also be economical by eliminating the need for a separate washing operation at your site.
- ▶ If washing must occur on-site, use designated, bermed wash areas to prevent wash water contact with storm water, creeks, rivers, and other water bodies. The wash area can be sloped for wash water collection and subsequent infiltration into the ground.
- ▶ Use as little water as possible to avoid having to install erosion and sediment controls for the wash area. Use phosphate-free biodegradable soaps. Educate employees and subcontractors on pollution prevention measures. Do not permit steam cleaning on-site. Steam cleaning can generate significant pollutant concentrations.

TARGETED POLLUTANTS

- Sediment
- Nutrients
- Toxic Materials
- Oil & Grease
- Floatable Materials
- Other Waste

- High Impact
- Medium Impact
- Low or Unknown Impact

LIMITATIONS:

- ▶ Even phosphate-free, biodegradable soaps have been shown to be toxic to fish before the soap degrades.
- ▶ Sending vehicles/equipment off-site should be done in conjunction with Stabilized Construction Entrance.

MAINTENANCE:

- ▶ Minimal, some berm repair may be necessary.

IMPLEMENTATION REQUIREMENTS

- Capital Costs
- O&M Costs
- Maintenance
- Training

- High Medium Low

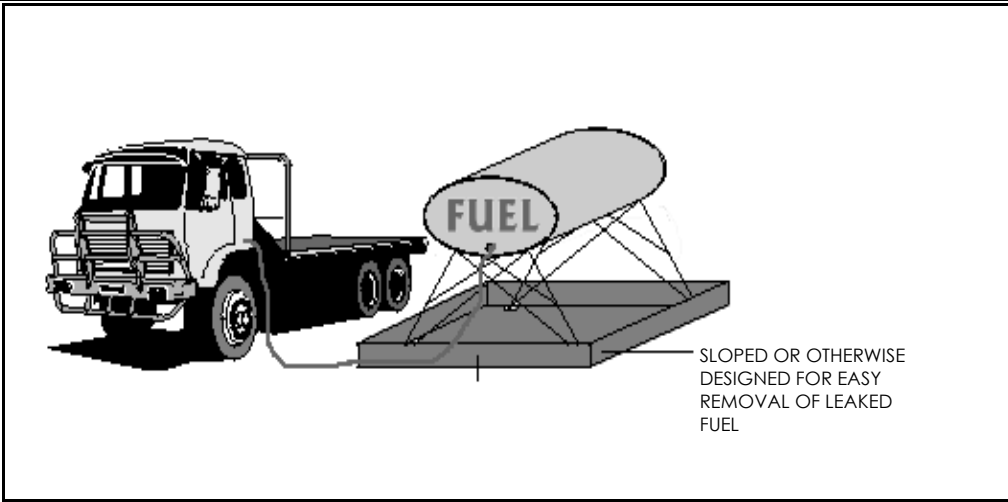

DESCRIPTION:

Prevent fuel spills and leaks, and reduce their impacts to storm water by using off-site facilities, fueling in designated areas only, enclosing or covering stored fuel, implementing spill controls, and training employees and subcontractors.

INSTALLATION/APPLICATION:

- ▶ Use off-site fueling stations as much as possible. Fueling vehicles and equipment outdoors or in areas where fuel may spill/leak onto paved surfaces or into drainage pathways can pollute storm water. If you fuel a large number of vehicles or pieces of equipment, consider using an off-site fueling station. These businesses are better equipped to handle fuel and spills properly. Performing this work off-site can also be economical by eliminating the need for a separate fueling area at your site.
- ▶ If fueling must occur on-site, use designated areas, located away from drainage courses, to prevent the runoff of storm water and the runoff of spills. Discourage "topping-off" of fuel tanks.
- ▶ Always use secondary containment, such as a drain pan or drop cloth, when fueling to catch spills/leaks. Place a stockpile of spill cleanup materials where it will be readily accessible. Use adsorbent materials on small spills rather than hosing down or burying the spill. Remove the adsorbent materials promptly and dispose of properly.
- ▶ Carry out all Federal and State requirements regarding stationary above ground storage tanks.(40 CF Sub. J) Avoid mobile fueling of mobile construction equipment around the site; rather, transport the equipment to designated fueling areas. With the exception of tracked equipment such as bulldozers and perhaps forklifts, most vehicles should be able to travel to a designated area with little lost time. Train employees and subcontractors in proper fueling and cleanup procedures.

LIMITATIONS:

Sending vehicles/equipment off-site should be done in conjunction with Stabilized Construction Entrance.

MAINTENANCE:

- ▶ Keep ample supplies of spill cleanup materials on-site.
- ▶ Inspect fueling areas and storage tanks on a regular schedule.

OBJECTIVES

- Housekeeping Practices
- Contain Waste
- Minimize Disturbed Areas
- Stabilize Disturbed Areas
- Protect Slopes/Channels
- Control Site Perimeter
- Control Internal Erosion



Adapted from Salt Lake County BMP Fact Sheet

TARGETED POLLUTANTS

- Sediment
- Nutrients
- Toxic Materials
- Oil & Grease
- Floatable Materials
- Other Waste

- High Impact
- Medium Impact
- Low or Unknown Impact

IMPLEMENTATION REQUIREMENTS

- Capital Costs
- O&M Costs
- Maintenance
- Training

- High Medium Low

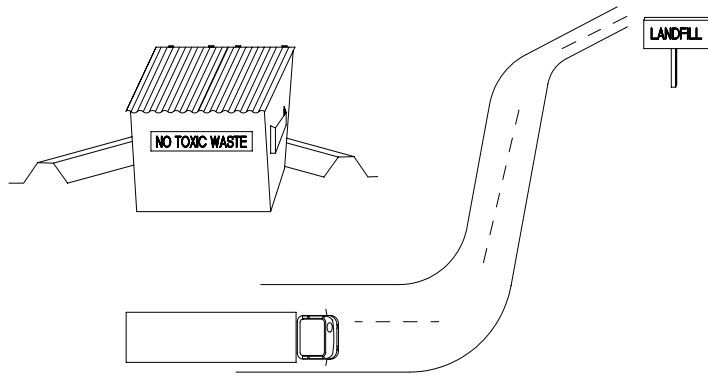

OBJECTIVES

- Housekeeping Practices
- Contain Waste
- Minimize Disturbed Areas
- Stabilize Disturbed Areas
- Protect Slopes/Channels
- Control Site Perimeter
- Control Internal Erosion

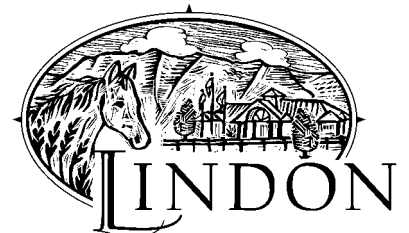

TARGETED POLLUTANTS

- Sediment
- Nutrients
- Toxic Materials
- Oil & Grease
- Floatable Materials
- Other Waste

- High Impact
- Medium Impact
- Low or Unknown Impact

IMPLEMENTATION REQUIREMENTS

- Capital Costs
- O&M Costs
- Maintenance
- Training

- High
- Medium
- Low

DESCRIPTION:

Controlled storage and disposal of solid waste generated by construction activities.

APPLICATION:

All construction sites.

INSTALLATION:

- ▶ Designate one or several waste collection areas with easy access for construction vehicles and personnel. Ensure no waterways or storm drainage inlets are located near the waste collection areas.
- ▶ Construct compacted earthen berm (See Earth Berm Barrier BMP Fact Sheet), or similar perimeter containment around collection area for impoundment in the case of spills and to trap any windblown trash.
- ▶ Use water tight containers with covers to remain closed when not in use. Provide separate containers for different waste types where appropriate and label clearly.
- ▶ Ensure all on site personnel are aware of and utilize designated waste collection area properly and for intended use only (e.g. all toxic, hazardous, or recyclable materials shall be properly disposed of separately from general construction waste).
- ▶ Arrange for periodic pickup, transfer and disposal of collected waste at an authorized disposal location. Include regular Porto-potty service in waste management activities.

LIMITATIONS:

- ▶ On-site personnel are responsible for correct disposal of waste.

MAINTENANCE:

- ▶ Discuss waste management procedures at progress meetings.
- ▶ Collect site trash daily and deposit in covered containers at designated collection areas.
- ▶ Check containers for leakage or inadequate covers and replace as needed.
- ▶ Randomly check disposed materials for any unauthorized waste (e.g. toxic materials).
- ▶ During daily site inspections check that waste is not being incorrectly disposed of on-site (e.g. burial, burning, surface discharge, discharge to storm drain).

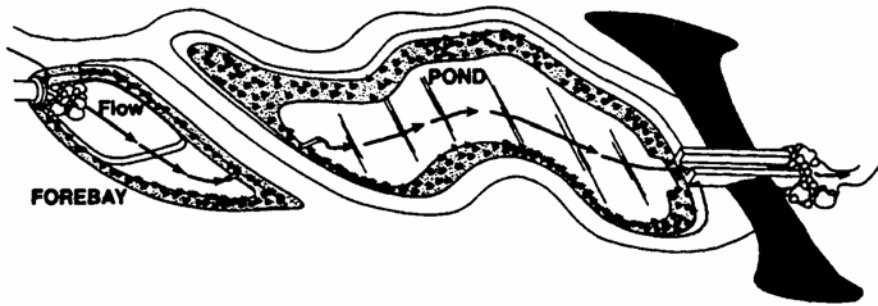

CONSIDERATIONS

- Soils
- Area Required
- Slope
- Water Availability
- Aesthetics
- Hydraulic Head
- Environmental Side Effects

DESCRIPTION:

A wet pond has a permanent water pool to treat incoming stormwater. An enhanced wet pond includes a pretreatment sediment forebay.

APPLICATION:

- ▶ Need to achieve high level of particulate and some dissolved contaminant removal.
- ▶ Ideal for large, regional tributary areas.
- ▶ Multiple benefits of passive recreation (e.g. bird watching, wildlife habitat).

INSTALLATION/APPLICATION CRITERIA:

- ▶ Water depth of 3 to 9 feet.
- ▶ Wetland vegetation, occupying 25-50% of water surface area.
- ▶ Design to minimize short-circuiting.
- ▶ Bypass storms greater than two year storm.
- ▶ Establishing wetland vegetation may be difficult.

LIMITATIONS:

- ▶ Concern for mosquitoes and maintaining oxygen in ponds.
- ▶ Cannot be placed on steep unstable slopes.
- ▶ Need base flow or supplemental water if water level is to be maintained.
- ▶ Infeasible in very dense urban areas.
- ▶ May require permits from various regulatory agencies, e.g., Corps of Engineers.

MAINTENANCE:

- ▶ Remove floatables and sediment build-up.
- ▶ Correct erosion spots in banks.
- ▶ Control mosquitoes.

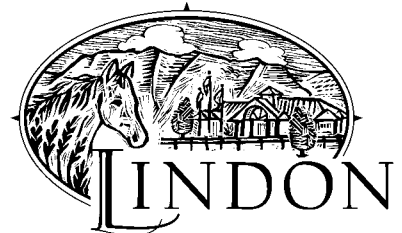

Adapted from Salt Lake County BMP Fact Sheet

TARGETED POLLUTANTS

- Sediment
- Nutrients
- Heavy Metals
- Toxic Materials
- Oxygen Demanding Substances
- Oil & Grease
- Floatable Materials
- Bacteria & Viruses

- High Impact
- Medium Impact
- Low or Unknown Impact

IMPLEMENTATION REQUIREMENTS

- Capital Costs
- O&M Costs
- Maintenance
- Training

- High Medium Low