

The Pretty Pinkeeper

Every stitcher needs a pin cushion or two, don't they?

And, right now, it seems stitchers are collecting them — lots of them!

Using buttonhole embroidery with wool makes

“The Pretty Pinkeeper” oh, so pretty!

It's pleasant, peaceful and portable handwork that finishes neatly and quickly.

Wool-on-wool applique is nice, of course, or try wool-on-cotton applique for a new, fresh look.

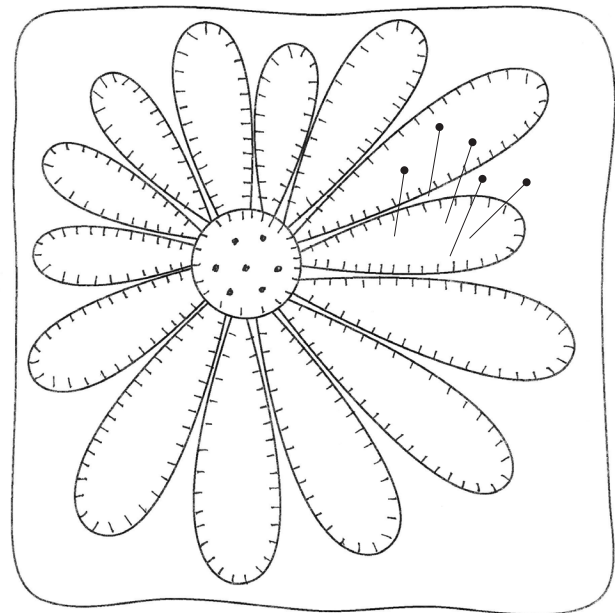

approximately 6" x 6"

Supplies needed

- background and backing — 1/4 yard wool or cotton fabric
- flower petals — 14 different scraps of wool at least 2" x 4"
- flower center — one scrap of wool at least 2" x 2"
- embroidery floss, wool thread or perle cotton in neutral or matching color
- optional trim for edge (lace, cording, crochet)
- stuffing (polyester or cotton, crushed walnut shells, emery sand)

Cut

 — read all directions before beginning

Note: Templates do not include seam allowances.

background and backing — cut two squares 7" x 7"

flower petals — cut as follows:

template A: cut four to use for petals 1, 2, 3 and 5

template B: cut four to use for petals 4, 6, 8 and 14

template C: cut two to use for petals 7 and 10

template D: cut one to use for petal 9

template E: cut three to use for petals 11, 12 and 13

flower center — template F: cut one

Directions

 — read all directions before beginning; all seams are 1/2-inch

1. Follow the placement diagram and use a buttonhole stitch to applique flower petals 1 through 14 in place.
2. Follow placement diagram and use a buttonhole stitch to applique flower center in place.
3. Refer to drawing above and embroider seven french knots in flower center.
4. With right-sides together and using a 1/2-inch seam, sew around the edges, leaving an opening at the bottom to turn the pinkeeper right-side out. Trim all four corners as shown in diagram at right.
5. Turn pinkeeper right-side out.
6. Stuff and sew the opening closed.

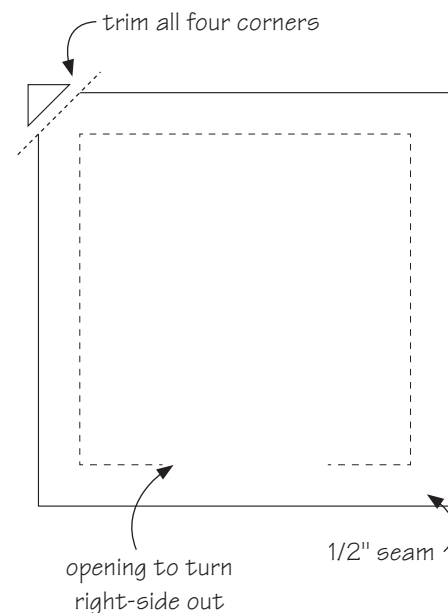

Note: templates do not include seam allowances

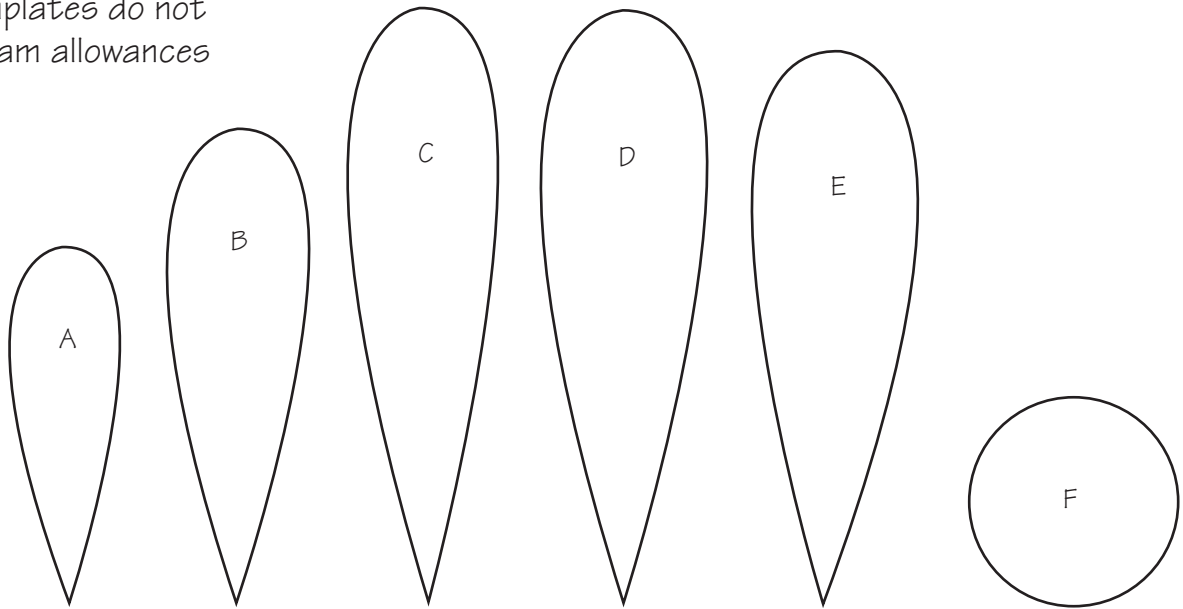

placement diagram

Note: The middle point of the flower center is $2\frac{7}{8}$ " down from the cut edge and $2\frac{5}{8}$ " to the right of the left-hand cut edge.

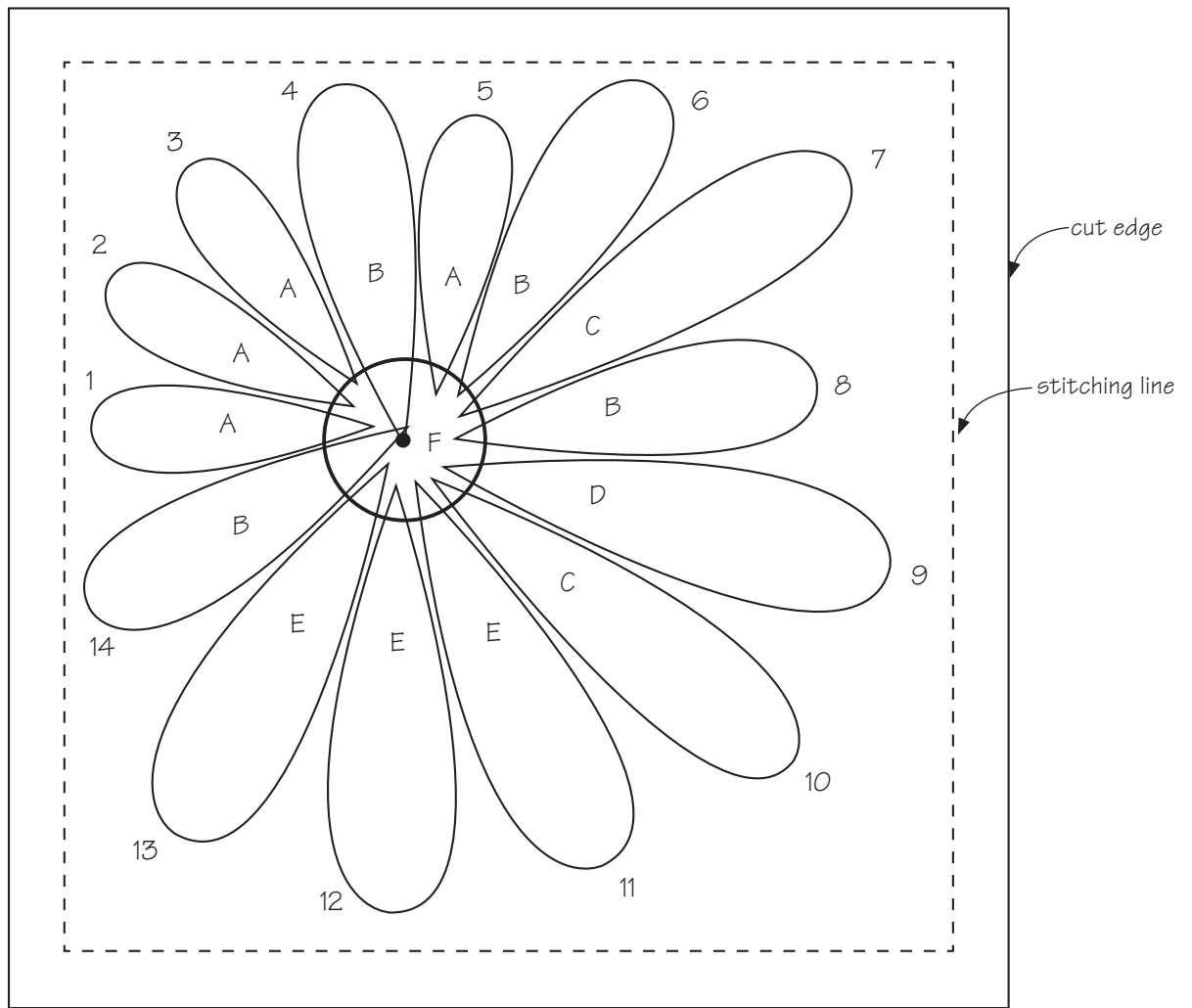

This pattern has been provided to you by: